

INNOVATION AT WORK

Non-contact application
of critical fluids



-  ANTIMICROBIAL
-  HYDROPHILIC
-  HYDROPHOBIC
-  FLAME RETARDANT
-  DIRT / SOIL REPELLENT
-  SKIN CARE & PARFUMING
-  UV-PROTECTION
-  ...WHATEVER YOU NEED

WEKO-ProTec - safe surface finishing
for nonwovens and technical, home, classical textiles

Worldwide the demand of specialized and individual products is raising and diversity of finishings is growing. More flexibility in production is required while consumption of chemicals, water and heat energy becomes a bigger point in terms of sustainability and optimizing the margins.

Therefore WEKO offers high precision and non-contact minimal application systems for a wide variety of fluids.

Convincing factors are the precise spray quantity and the perfect reproducibility. The contact-free application prevents contamination of your chemical bath as well as uneven treatment across the entire production. Due to one or both side spray and high flexibility in recipe your chemical use could easily be reduced with full functionality. Low tank volumes, rinsing and cleaning processes helping to reduce your waste after production. The system is designed for 100 % speed compensation up to 1200 m/min. and a spray width from 0,5 up to 7,5 meter.

In addition, WEKO-ProTec, the encapsulated application unit, allows you to safely handle substances that should not be perceivable in your working environment. This may include aerosols exhibiting unpleasant odours or slippery silicones and oils. With the encapsulation and highly efficient extraction, WEKO provides a solution that reduces the health risk at the workplace.

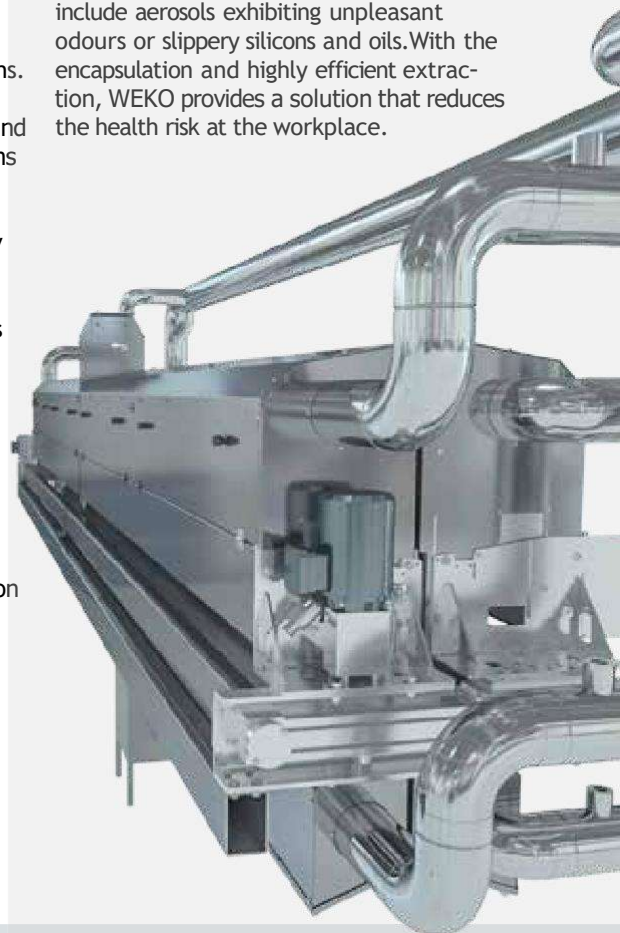

MAXIMUM SAFETY FOR PEOPLE AND THE MACHINE



Principle of the non-contact WEKO application system:

The fluid is supplied to the center of fast rotating discs which speeds it up and distribute it's due to centrifugal force to the disc edge. Liquid threads are built which are mechanically separated to an even 360° stream of micro droplets by overcoming the cohesive forces. Special covers creating precise spraying fans. To reach the needed spray format several rotor discs are installed beside each other in the WEKO rotor carrier.

Advantages of the non-contact application:

- **NO STRAIN FOR THE MATERIAL WEB**
thanks to non-contact application
- **MAXIMUM PROCESS RELIABILITY**
thanks to precise and reproducible spray amount
- **SAVING UP TO 70% OF CHEMICALS AND WATER**
- **SAVING UP TO 90% OF HEAT ENERGY**

Protection against:

harmful aerosols



unpleasant odours



risk of slipping



Principle of WEKO-ProTec encapsulation:

The significant improvement of protection against undesirably escaping aerosols and the cleanliness of the environment is achieved through the very easy to operated encapsulated application unit. By push on a button it is automatically opening and the material could easily be feeded in. After closing, the high efficient extraction provides the desired protection.

Benefits of WEKO-ProTec:

- **PROTECTION OF THE WORKERS' HEALTH**
- **SAFETY AT THE WORKPLACE**



APPLICATIONS

- **MEDICAL SUPPLIES**, e.g. surgical gowns, surgical drapes, face masks
- **HYGIENE ARTICLES**, e.g. diapers, fem care, incontinence products
- **HOME TEXTILES**, e.g. mattress, bedding, sofa covers
- **APPAREL**, e.g. outdoor & sport fashion, workwear
- **AUTOMOTIVE**, e.g. seats, headliner, tufted carpets