



HEIDENHAIN

Votre agent :

araxe

72, rue Yves le Coz
78000 - VERSAILLES

tél : 01 30 21 48 49
contact@araxe.com

<http://www.araxe.com>



Measuring Systems

For Machine Tool Inspection and
Acceptance Testing

September 2007

Machine tool performance from the point of view of compliances to tolerances, surface definition, etc., is determined essentially by the accuracy of machine movement.

For precision machining it is therefore important to measure and compensate for deviations in motion. Standards and directives for inspecting machine tools, such as ISO 230-2, ISO 230-3, ISO 230-4 and VDI/DGQ 3441, stipulate a number of measuring methods for determining static and dynamic deviations.

In combination with their powerful evaluation software, measuring systems from HEIDENHAIN for inspection and acceptance testing of machine tools make precise and informative measurements of the machine possible with a minimum of mounting and adjustment efforts.

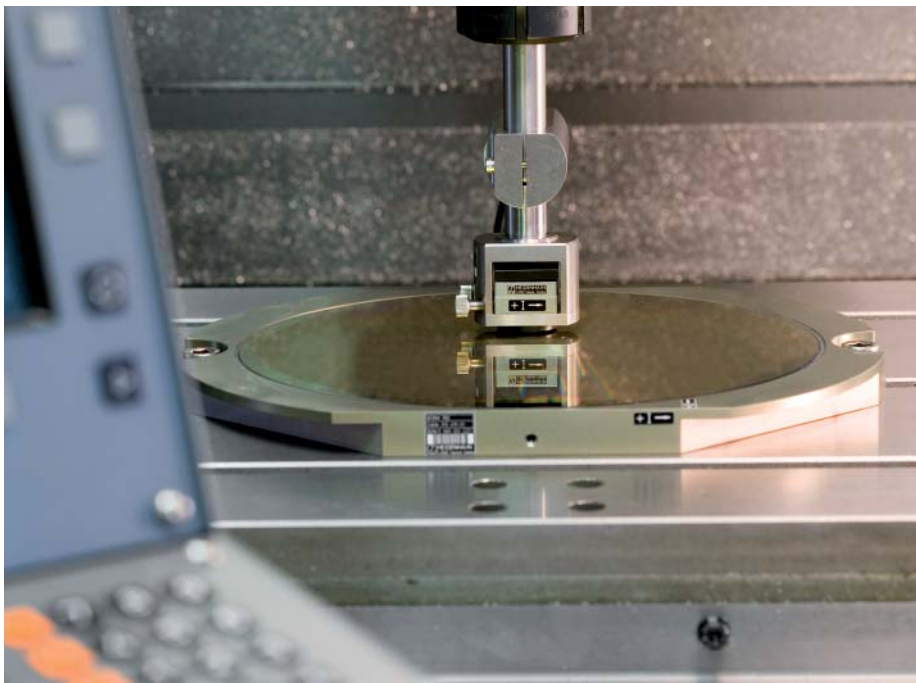

Contents

Introduction			
	Areas of Application		4
	Configuration		5
Measurement Methods			
	ACCOM Evaluation Software		6
	Dynamic Measurements	<ul style="list-style-type: none"> • Circular interpolation test • Free-form test • Step response test 	6
	Static Measurement	<ul style="list-style-type: none"> • Positioning accuracy • Guideway error 	8
	Measurement of the Thermal Drift		9
Measuring Systems for Inspecting Linear Axes			
	KGM 181 KGM 182	Grid encoders for <ul style="list-style-type: none"> • Short linear movements • Circular movements • Free-form tests 	10
	VM 182	Comparator measuring system for <ul style="list-style-type: none"> • Linear axes • Guideway errors 	12
Measuring Systems for Inspecting Rotary Axes			
	General Information	Fundamentals and mounting instructions	14
	Angle Encoders	Overview of ROD 880, RON 886, RPN 886, RON 905	15
Accessories			
	IK 220	PC counter card	16
	Adapter Cables		17

Introduction

Areas of Application

Conventional inspection and acceptance testing of machine tools is limited essentially to static measurement of the geometrical machine structure without load and—on controlled machines—to measuring positioning accuracy. The final results of machining are increasingly influenced by dynamic deviations from the nominal contour and by high acceleration rates in the machine tool. Therefore, test workpieces are produced and inspected for dimensional accuracy in order to draw conclusions about the dynamic behavior of the machine.

HEIDENHAIN offers measuring systems for direct capture of **dynamic and static** deviations. The advantage of this direct inspection method over simply inspecting the results of the machining lies in its separation of technological influences from machine influences, and in its capability of distinguishing individual factors of influence.

Dynamic measurements—especially at high traversing speeds—provide information on contouring behavior that permits conclusions about both the condition of the machine tool as well as the parameter settings of the control loop consisting of the CNC control, drives, and position feedback systems. This information can be used to optimize the behavior of the machine (e.g. kv factor, reversal peaks)

Static measurements, such as the measurement of position error in linear and rotary axes using a comparator system, permit conclusions about the geometric accuracy and thermal behavior of the machine.

Machine tool builders use the results of machine measurements to develop constructive measures for improving accuracy. Such measurements also help them to optimize the commissioning parameters of the control loop wherever they influence the accuracy of a CNC machine.

Machine-tool users can use the measuring systems for acceptance testing and regular accuracy inspection of their machine.

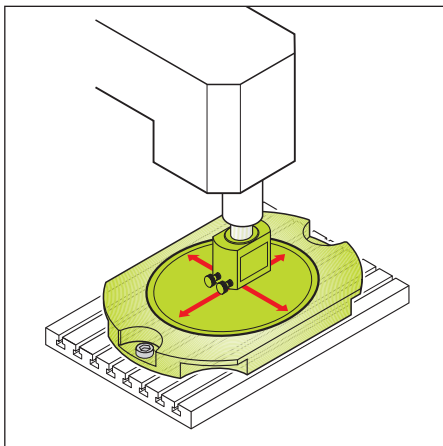

Circular interpolation tests with very small radii and free-form tests provide information on the dynamic behavior of the control, and circular interpolation tests with large radii provide information on the machine geometry.

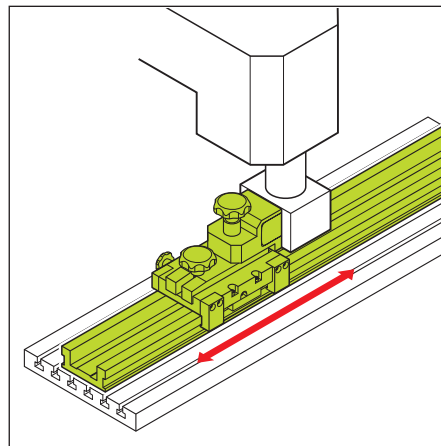

Position accuracy and repeatability, as well as guideway errors of linear machine axes, are determined with a comparator system.

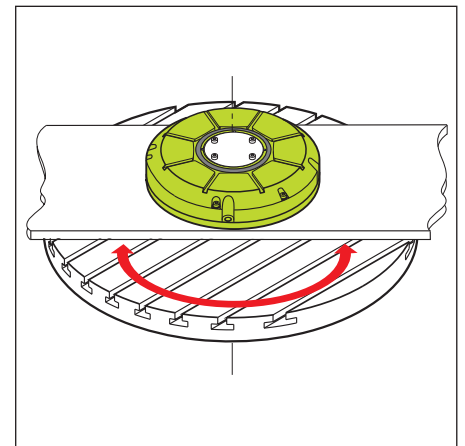

The position accuracy and repeatability of rotary axes, rotary tables and tilting tables can also be determined. A very precise angle encoder serves as comparator system.

Configuration

A typical setup for inspecting a machine tool consists of the following components:

- Measuring system for inspecting axis movements (KGM, VM or angle encoder)
- PC with IK 220 PC counter card and ACCOM evaluation software

The measuring systems for inspection of linear axes—KGM 181 or KGM 182 grid encoder and VM 182 comparator system—measure the actual path of traverse without contact but highly dynamically. Both measuring systems permit a highly accurate, real two-dimensional measurement.

Angle encoders are used to measure rotary axes. They are attached to the rotary table or tilting axis, and are connected to the stationary machine element via a measuring bridge.

Since the inspection setup operates completely independently, no communication is necessary between the PC and the CNC. Machines with any type of control can be inspected. The ACCOM evaluation software simply needs to be used to program the same traverse motions on the CNC and on the PC.

ACCOM offers the possibilities of importing NC programs as well as exporting the test NC programs created with ACCOM. This reduces programming efforts, since, for example, free-form contours can simply and quickly be loaded from existing NC programs. HEIDENHAIN plain-language programs can easily be exchanged directly between a TNC control from HEIDENHAIN and the PC. DIN/ISO programs in simplified G-code format can also be imported by ACCOM.

ACCOM automatically detects the beginning of the inspection procedure—for example when a certain distance or angle has been moved from the starting position.

Measuring points are also recorded automatically whenever predefined conditions have been fulfilled (position window, speed window).

The measured data is processed by ACCOM, and then displayed in a clearly understandable manner. The data can also be loaded by other programs (e.g. Matlab, Origin, Excel, etc.), since they are saved in ASCII format.

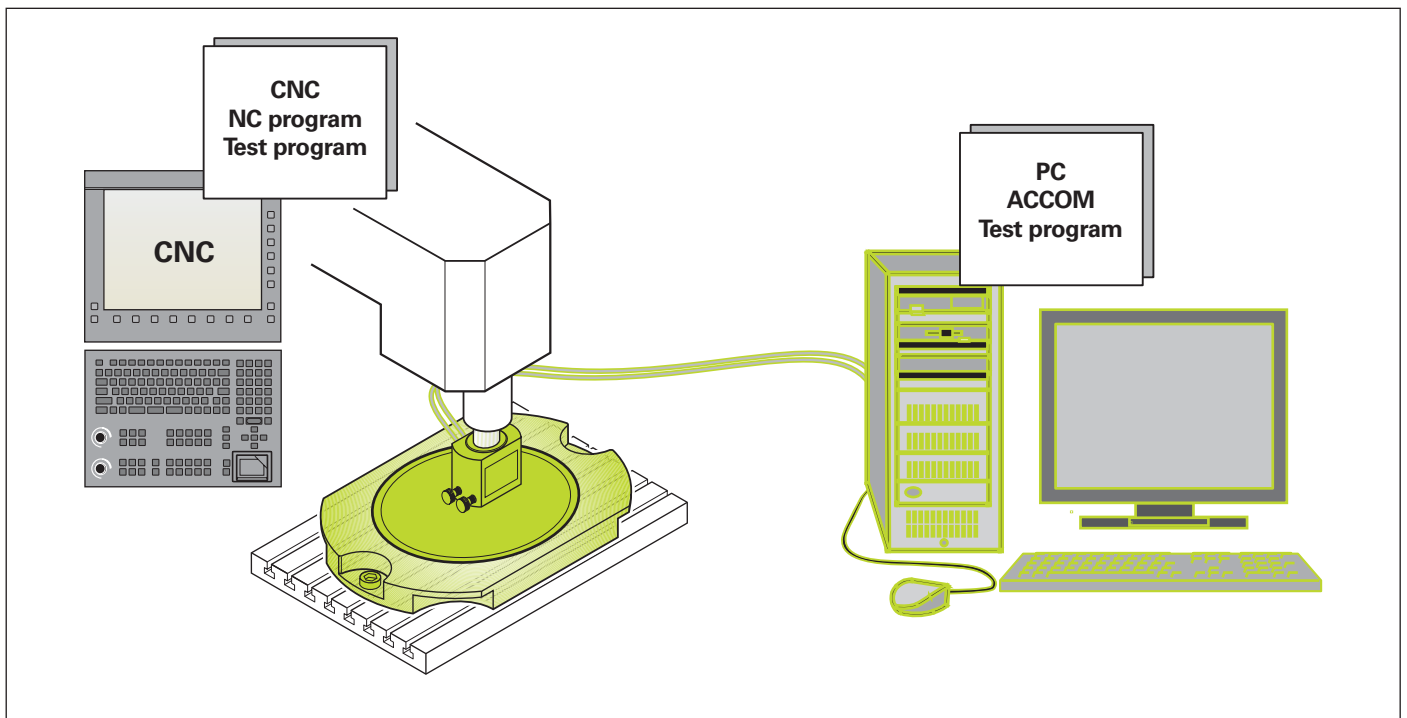

Measurement Methods

ACCOM Evaluation Software

The measurement methods for inspection and acceptance testing of machine tools are regulated by national and international standards and directives. The **ACCOM Evaluation Software for PCs** from HEIDENHAIN is an easy-to-use program for measured value acquisition and

evaluation according to the ISO 230-2, ISO 230-3, ISO 230-4 and ISO 10791-6 (K2 and K3) standards, as well as the VDI/DGQ directive 3441. The ACCOM evaluation software runs on all PCs with Windows 98SE/2000/XP.

Dynamic Measurements

Circular interpolation test

In the circular interpolation test, the CNC control performs a circular interpolation in the working plane.

The ACCOM evaluation software compares the values measured by the grid encoder with the ideal (programmed) circular path, and shows the deviations enlarged on the PC screen. ACCOM also calculates the numerical values, such as circular error, circular backlash and radial error, according to ISO 230-4.

The data measured with the circular interpolation tests permit conclusions about the causes of the errors:

- Orthogonality errors of the machine axes
- Reversal peaks at quadrant transitions
- Hysteresis, reversal error
- Incorrect error compensation values in the control
- Errors resulting from irregular thermal expansion of machine components
- Tilt and sag in the machine axes
- Axis adjustments
- Influences of traversing speeds
- Influence of acceleration

Circular interpolation tests performed over large radii provide information on the machine geometry. On the other hand, circular interpolation tests with small radii provide information on the accuracy of the control under high axis acceleration rates. The influence of the machine geometry on the measuring results of tests with small radii is insignificant. The control and drives, however, have a very strong effect.

Circular interpolation tests are performed with the **KGM 181** and **KGM 182** grid encoders.

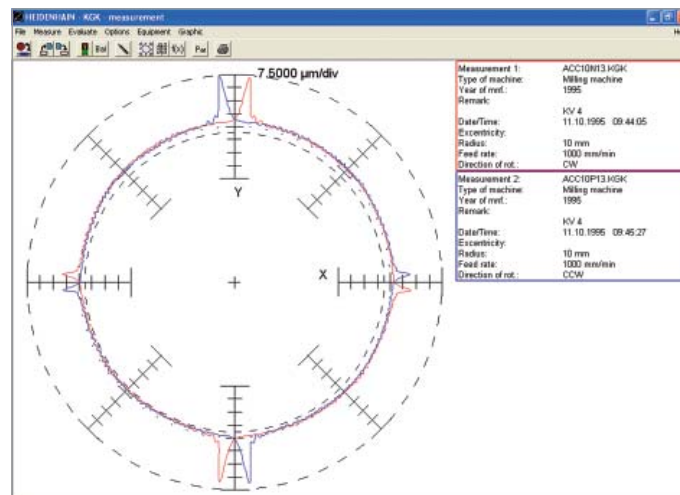

Standardized representation of a circular interpolation test with a KGM: The reversal peaks at the quadrant transitions are visible, as is the difference between clockwise and counterclockwise traverse

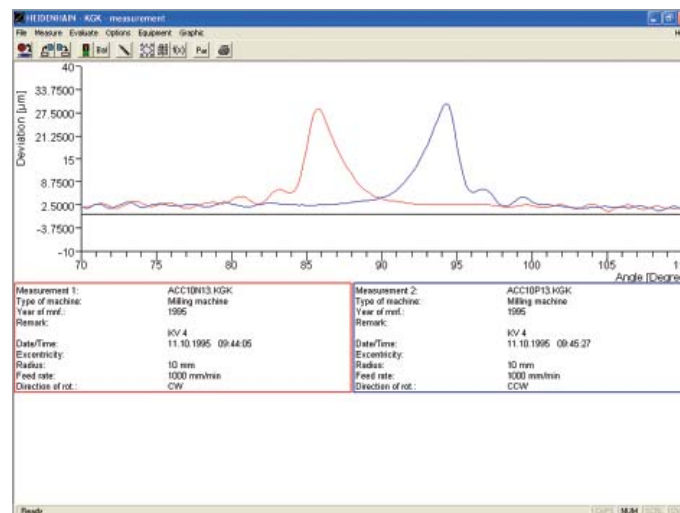

The line graph shows a magnified view of the reversal peaks at 90°

Free-form test

In the free-form test, the CNC moves the machine axes in a plane on any programmed path. The KGM is used to measure the path actually traversed. ACCOM displays the errors in various views. The dynamic behavior of the machine can be evaluated at corners and transitions in the contour. Free-form paths as per ISO 10791—K2 feed rates and K3 interpolation of two axes—can be inspected.

Free-form tests are performed with the **KGM 181** and **KGM 182** grid encoders.

The free form shown features some interesting contour transitions:

- Continuous transition from line to arc
- Continuous transition from arc to line
- Abrupt transition from line to arc
- Abrupt transition from arc to line
- Abrupt transition from line to line

Other typical free-form tests can be performed with the KGM to detect the following errors or effects of the control or mechanics, for example:

- Orthogonality of two axes (large cross)
- Natural frequencies (slanted lines at approx. 45°, corners)
- Path interpolation of two axes (slanted lines at smaller angles)

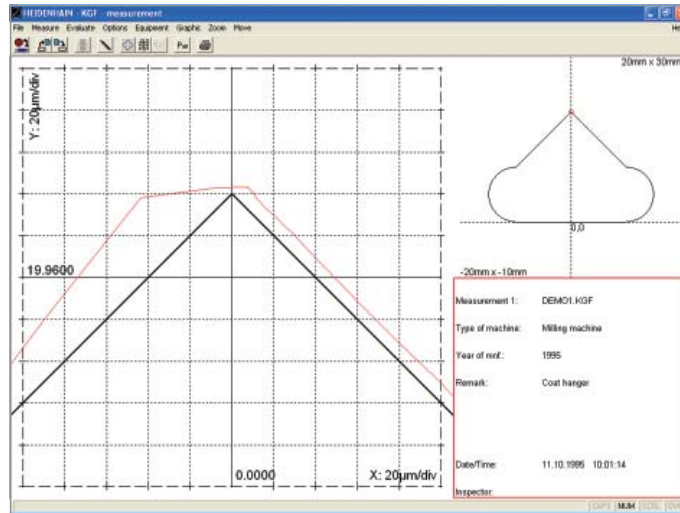

Standardized representation of a free-form test with a KGM and detail zoom: here a normal view shows an overshoot with the resulting rounding-off error (nominal path: black; actual path: red).

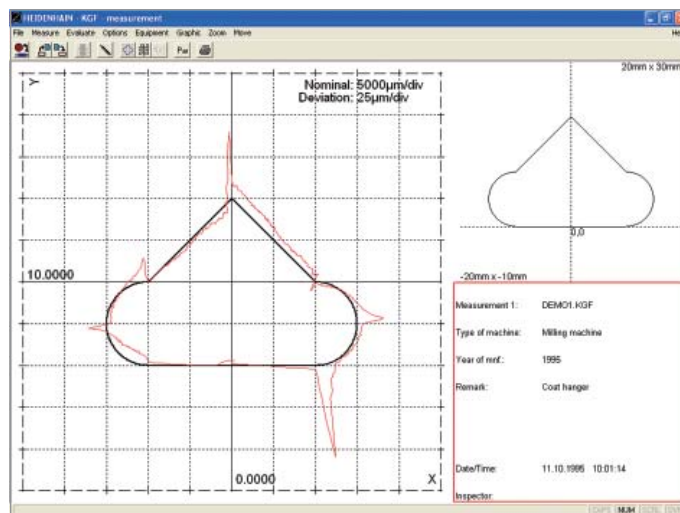

Result of a free-form test with excessive errors

Step response test

The step response test can be used to measure the smallest possible positioning increment (step-response function) and provide information on the influence of static friction and the accuracy with which positions can be held. This test is also intended for high-precision tasks requiring increments of as small as 0.1 µm to 0.01 µm. ACCOM permits graphical representation of distance over time (Xt, Yt) and of speed over time (vt).

The step response test can be performed with **KGM 181** and **KGM 182** grid encoders as well as with the **VM 182** comparator system.

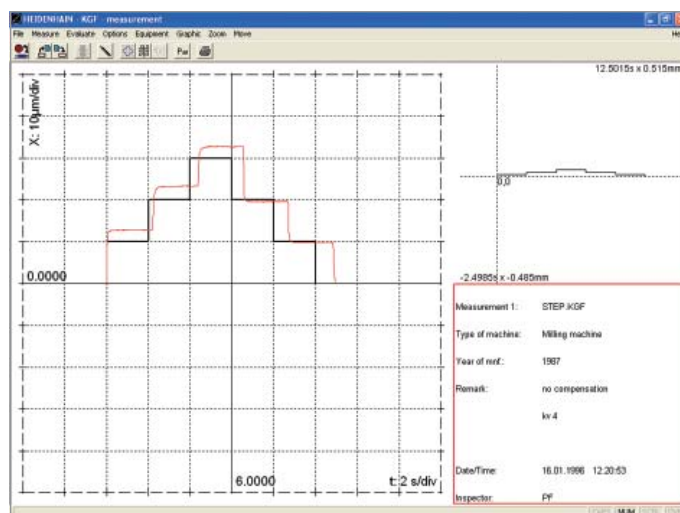

Result of a step response test as an "Xt" graph

Measurement Methods

Static Measurements

The positioning accuracy and repeatability of a machine tool is measured after the machine axis has been moved to certain positions.

Determining the static positioning accuracy of linear axes

The VM and KGM can be used to determine the positioning accuracy of a machine tool when moving machine axes to specified positions. Besides the positioning accuracy, these devices can also measure the guideway error perpendicular to the direction of the machine tool's slide.

ACCOM displays the errors clearly according to the respective standards.

Small traverse paths up to 230 mm can be measured with **KGM 181** and **KGM 182** grid encoders, larger traverse paths up to 1520 mm can be measured with the **VM 182** comparator system.

Determining the static positioning accuracy of rotary axes

By using an angle encoder as reference, any angular positions can be traversed to, and a detailed graph of the accuracy can be recorded.

The high-precision **ROD**, **RON** or **RPN** angle encoders from HEIDENHAIN are used to determine the positioning accuracy of rotary encoders.

ACCOM evaluates the measurement and displays the results clearly.

The example shows the graphs of two high-resolution measurements of a rotary table with a worm gear. The figure above illustrates position feedback via the rotary encoder in the motor ("semiclosed loop"). It shows the errors caused by the worm shaft (short-wave oscillations) and the worm wheel (long-wave oscillations) of the rotary table. The measurement of the same rotary table but with an angle encoder integrated for position capture ("closed loop") shows a much smaller range of error.

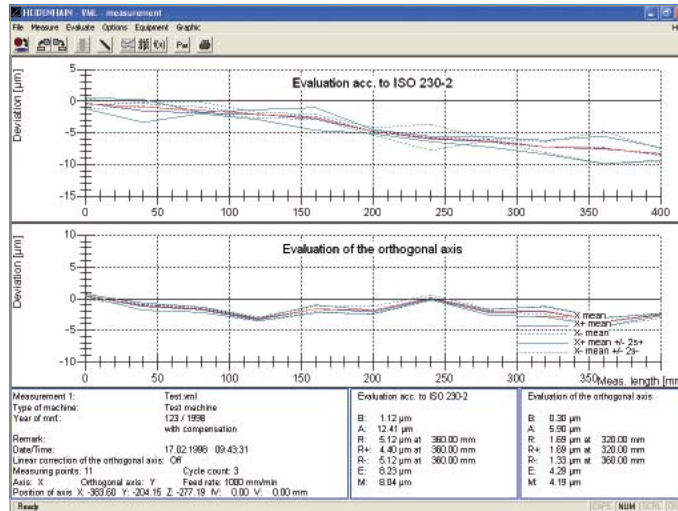

Measurement of the static positioning accuracy as per ISO 230-2 and the guideway error in transverse direction with the VM 182

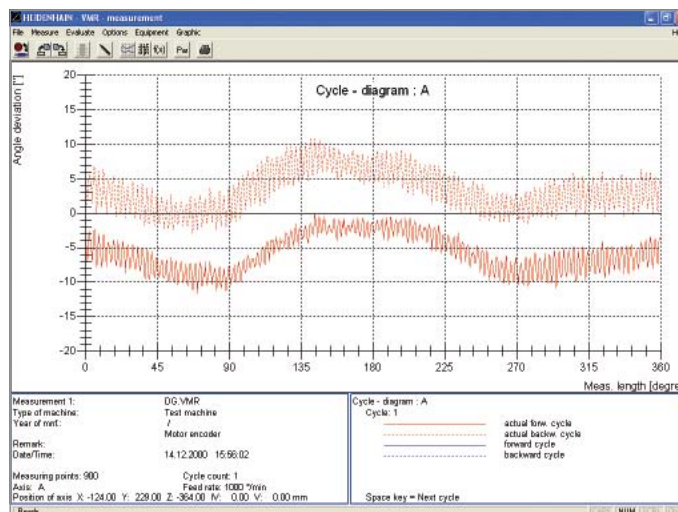

Measurement of the static positioning accuracy of a rotary table with worm gear with the RON 905 and feedback via the rotary encoder in the motor ("semiclosed loop") ...

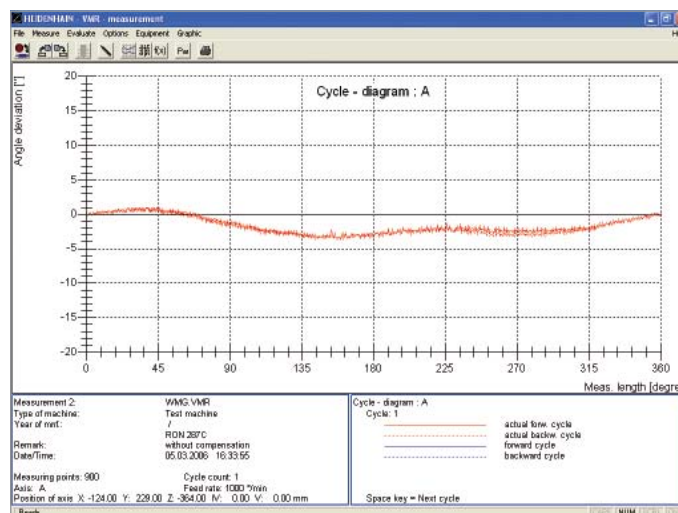

... and for feedback via an angle encoder ("closed loop")

Measurement of the Thermal Drift

Determining the thermal behavior of feed axes

The influence of frictional heat in ball screws of linear axes or worm gears of rotary axes on the position behavior of the feed axis becomes obvious when positioning tests are performed as per the ISO 230-3 standard. This standard contains recommendations for making uniform measurements of thermal shifts of lathes and milling machines as a result of external and internal heat sources.

To test the feed axes, it proposes a repeated positioning to two points that lie as near as possible to the ends of the traverse range at an agreed percentage of the rapid traverse velocity. The change of the positions with respect to the initial value is recorded. The test is to be conducted until a saturation effect is clearly observable.

The example shows the graphs of two measurements on a linear axis. The upper graph, with a rotary encoder in the motor for position capture, shows increasing position errors over time due to heating of the ball screw. The same measurement of the linear axis, but with a linear encoder for position capture, is shown below. The position errors are independent of the heating of the ball screw, since the linear encoder always captures the actual position of the axis slide.

The thermal behavior of linear axes is measured with **KGM 181** or **KGM 182** encoders, or with the **VM 182** comparator system for longer traverse paths. The **ROD, RON** or **RPN** angle encoders are used for rotary axes.

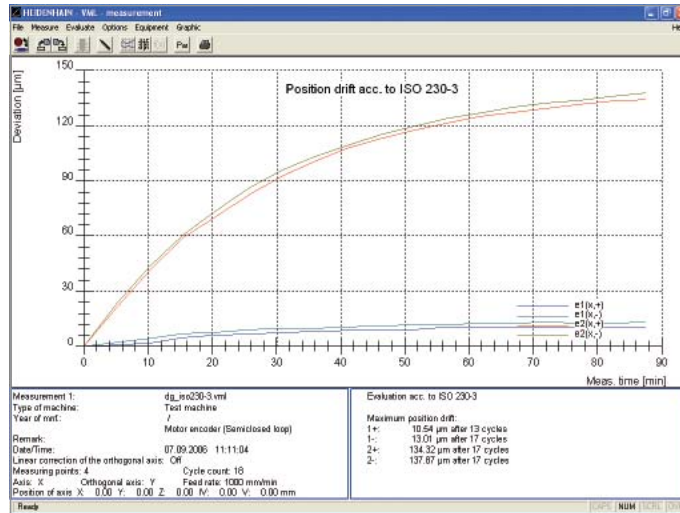

Determining the **thermal behavior** of a linear axis as per ISO 230-3 measurement with the VM 182 and feedback via the rotary encoder in the motor ("semiclosed loop") ...

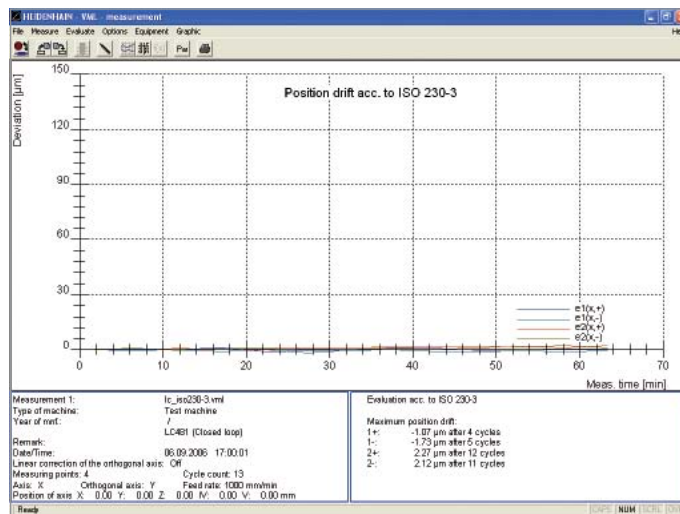

... and for feedback via a linear encoder ("closed loop")

Further information on this topic can be found in the Technical Information sheets

- Accuracy of Feed Axes
- Linear Encoders Improve the Machining Accuracy

Measuring Systems for Inspecting Linear Axes

KGM 181 and KGM 182 Grid Encoders

The KGM grid encoders consist of a grid plate with a waffle-type graduation, which is embedded in a mounting base, and a scanning head. During measurement, the scanning head moves over the grid plate without making mechanical contact. The KGM encoders capture any motions in a plane, and output the values measured for the two axes separately.

Area of application

The KGM encoders dynamically test the contouring accuracy of controlled machine tools. For example, they make **circular interpolation tests** with radii ranging from 115 mm down to 0.1 mm at feed rates up to 80 m/min possible. Especially at very small radii, the errors resulting from the machine's geometry no longer have an influence on the measurement results.

The contact-free scanning also permits **free-form tests** over any contours in two axes.

Measuring setup

For setup, the mounting base is fixed onto the workpiece-holding element (such as the machining table) and aligned to the axes. The scanning head is mounted on the tool-holding element (for example, the spindle of a machining center) so that it cannot rotate and is also approximately aligned to the axes.

An adjustment plate is included in delivery for simple adjustment of the scanning gap to 0.5 ± 0.05 mm. The setting screws of the scanning head are then used for the fine adjustment. They are used to optimize the measurement signals displayed in the ACCOM evaluation software.

Items supplied:

- KGM 181 or KGM 182
- Adapter for mounting the scanning head at an angle of 90° (for mating diameter: 20 mm)
- Mounting kit for XZ/YZ plane (only with KGM 181)

Accessories:

- IK 220 counter card for PCs
- ACCOM evaluation software
- Two adapter cables: KGM – IK 220

		KGM 181	KGM 182
Measuring standard	Expansion coefficient	Two-coordinate TITANID phase grating $\alpha_{\text{therm}} \approx 8 \times 10^{-6} \text{ K}^{-1}$	
Accuracy grade		$\pm 2 \mu\text{m}$	
Measuring range		$\varnothing 140 \text{ mm}$	$\varnothing 230 \text{ mm}$
Incremental signals		$\sim 1 \text{ V}_{\text{PP}}$	
Signal period		4 μm in measuring directions I and II	
Measuring step		$\geq 0.001 \mu\text{m}$ (with IK 220)	
Power supply		5V $\pm 5 \%$ / < 100 mA (per axis)	
Mount for scanning unit		$\varnothing 20\text{h7}$	
Traversing speed		$\leq 80 \text{ m/min}$	
Weight	Grid plate Scanning head	Approx. 4.0 kg Approx. 0.6 kg	Approx. 3.1 kg Approx. 0.6 kg

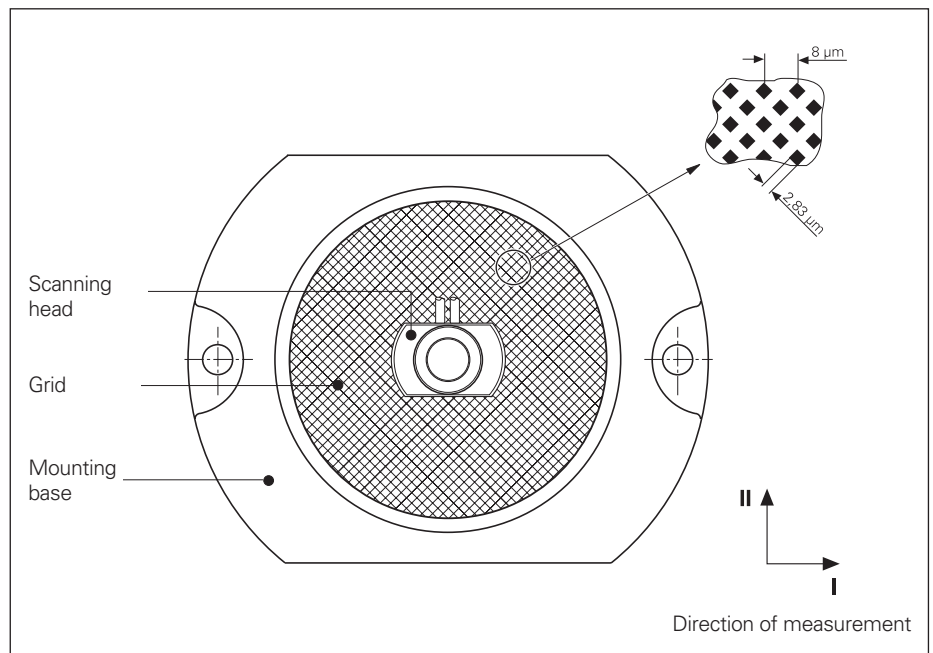

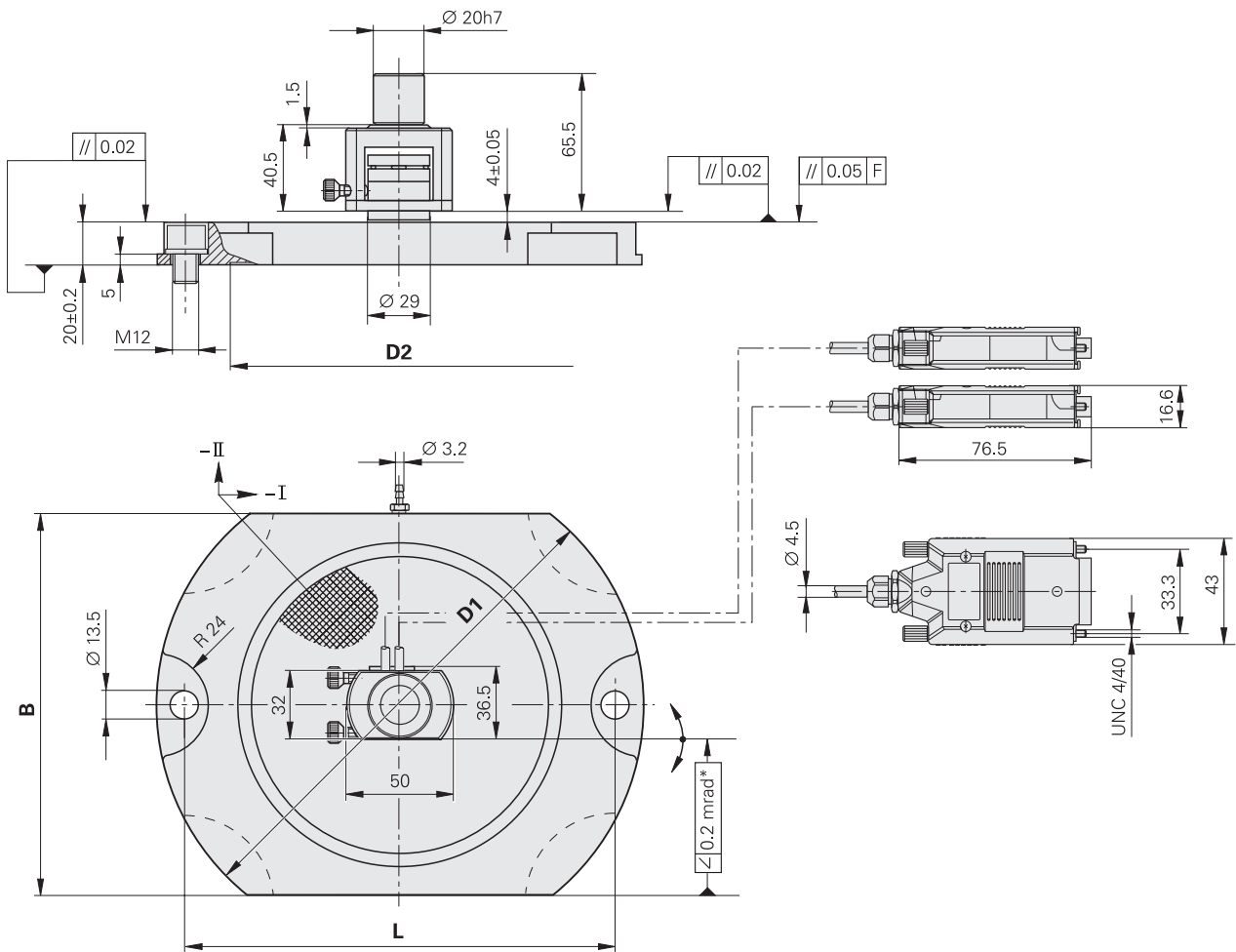
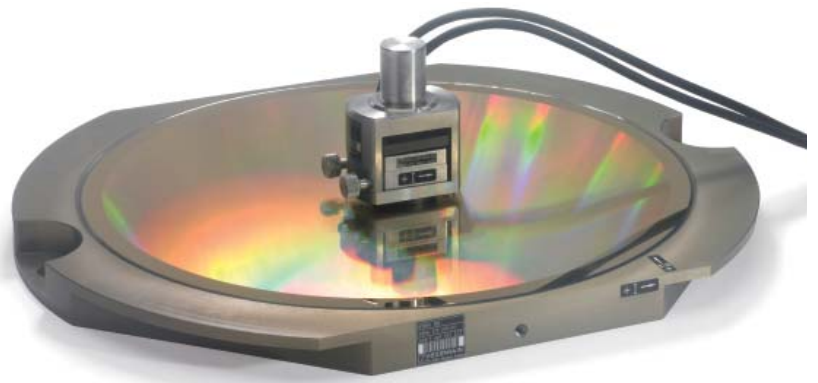

Dimensions in mm



Tolerancing ISO 8015
 ISO 2768 - m H
 < 6 mm: ±0.2 mm

	KGM 181	KGM 182
L	204	304
B	180	280
D1	Ø 228	Ø 328
D2	Ø 160	Ø 260

I, II = Directions of measurement
 F = Machine guideway
 * = Max. change during operation

Measuring Systems for Inspecting Linear Axes

VM 182 – Comparator System

The VM 182 comparator system incorporates a scale with a very precise two-coordinate phase grating and a scanning head that moves over the grating without mechanical contact. The scale is embedded in a massive, U-shaped steel profile, and can therefore be mounted directly on the machine table. Along with the measuring position in longitudinal direction, the VM 182 also captures small errors (± 1 mm) perpendicular to the direction of measurement.

Area of application

The VM 182 serves for acceptance testing, inspection and calibration of machine tools and measuring equipment with traverse ranges up to 1520 mm. Machine tool builders and distributors can use the VM 182 to determine the linear and nonlinear error curves as well as the reversal error of machine axes according to ISO 230-2. Along with the position error, it also measures the guideway error orthogonal to the traverse direction of the machine axis.

Measuring setup

During mounting the scanning head is connected to the scale by an auxiliary carriage. The scale is clamped paraxially onto the machine table and the scanning head is connected to the machine spindle with a coupling magnet. After mounting is completed, the auxiliary carriage is removed from the scanning head. The generous mounting tolerance simplify installation of the VM 182.

Items supplied:

- VM 182

Accessories:

- Bracket for attaching the scanning head to the machine spindle
- IK 220 counter card for PCs
- ACCOM evaluation software
- Two adapter cables: VM – IK 220

		VM 182
Measuring standard	Expansion coefficient	Two-coordinate DIADUR phase grating $\alpha_{\text{therm}} \approx 10 \times 10^{-6} \text{ K}^{-1}$
Accuracy grade		$\pm 1 \mu\text{m}$ in longitudinal direction $\pm 1.5 \mu\text{m}$ in transverse direction
Measuring length ML	(longitudinal direction) in mm	420 520 720 1020 1220 1520
Measuring range	(transverse direction)	± 1 mm
Reference mark		1 reference mark at beginning of measuring length
Incremental signals		$\sim 1 \text{ V}_{\text{PP}}$
Signal period		$4 \mu\text{m}$ in longitudinal and transverse direction
Measuring step		$\geq 0.001 \mu\text{m}$ (with IK 220)
Power supply		$5 \text{ V} \pm 5 \%$ / $< 100 \text{ mA}$ (per axis)
Coupling		Magnetically to a plane surface; bracket available as accessory
Traversing speed		$\leq 80 \text{ m/min}$
Weight	Scale Scanning head	Approx. 340 g + 6.7 g/mm ML Approx. 1.86 kg

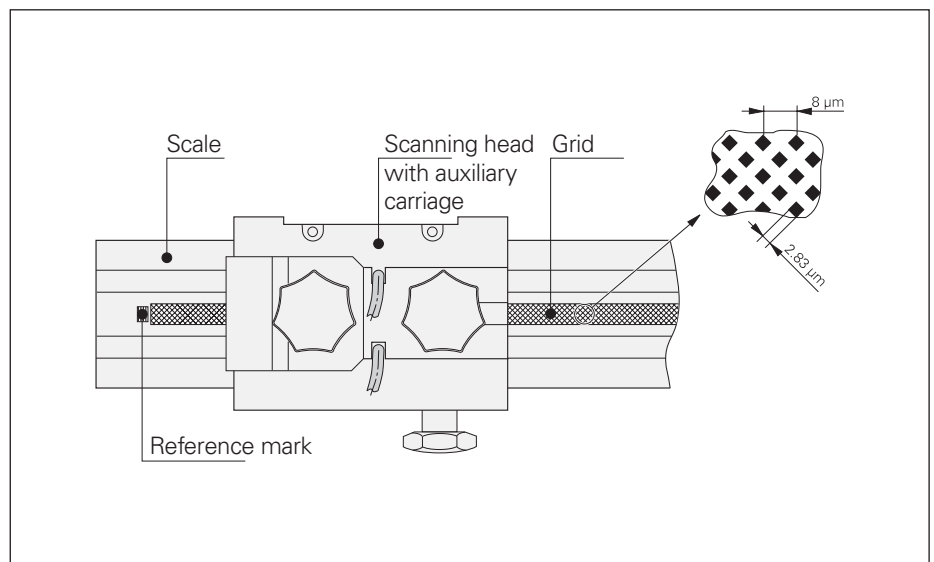

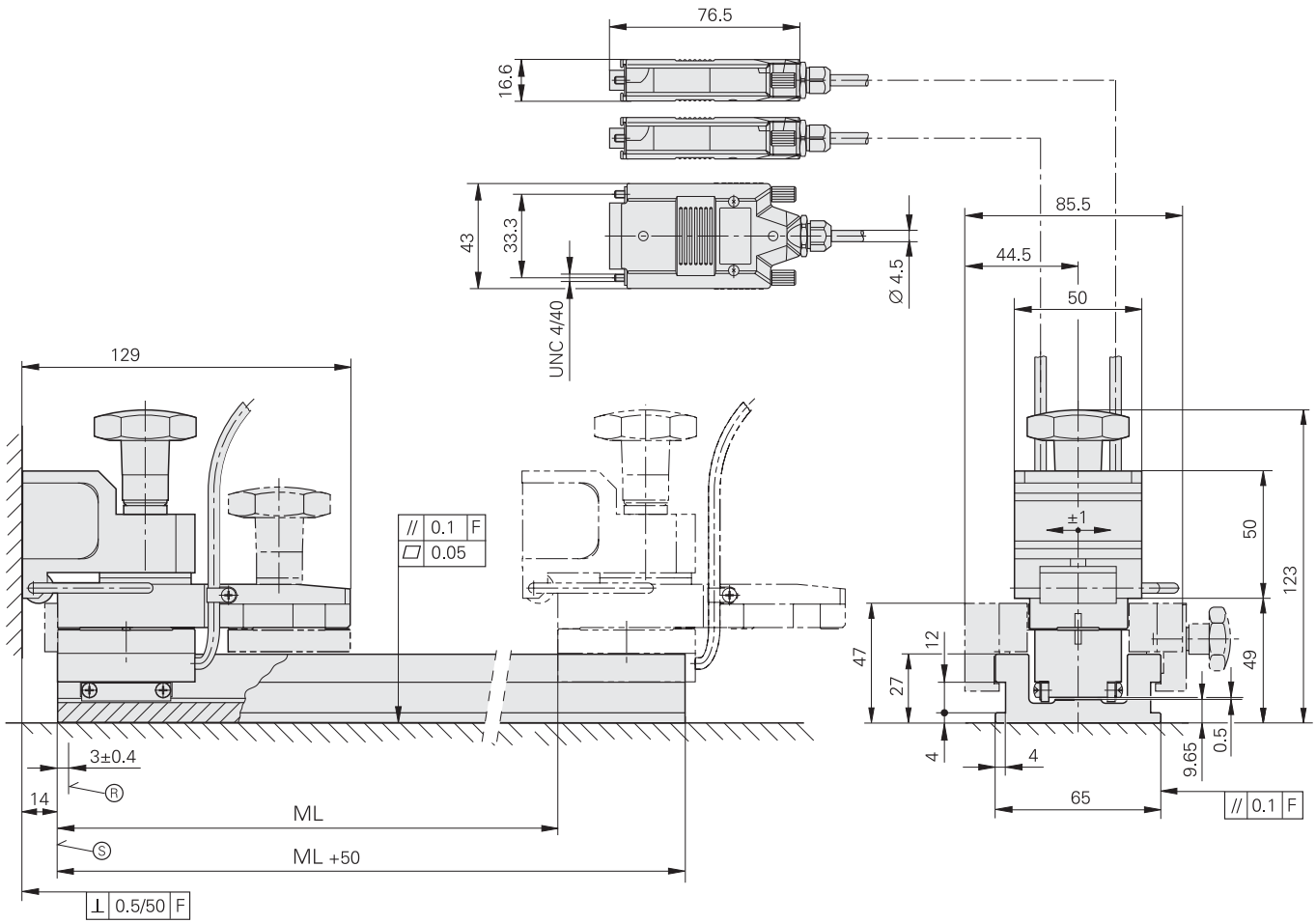

Dimensions in mm

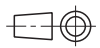

Tolerancing ISO 8015

ISO 2768 - m H

< 6 mm: ±0.2 mm

F = Machine guideway

Ⓜ = Position of reference mark

Ⓢ = Beginning of measuring length (ML)

Measurement of Rotary Axes

General Information

HEIDENHAIN offers high-precision angle encoders for the measurement of rotary axes. They permit measurements at any positions. Since no restrictions, such as 12 positions per 360°, are necessary, short-wave position errors can also be captured.

In addition, angle encoders make highly dynamic motions of the rotary table between the points of measurement possible (as per ISO 230-3).

Areas of application

The position errors of rotary axes (rotary or tilting tables, swivel heads) are often decisive factors in a machine's overall accuracy.

At this time, rotary and tilting axes are not involved as simultaneously moving axes in most cases. The positioning accuracy, as per ISO 230-2 for example, is definitive for such index axes. In addition, the dynamic and thermal behavior according to ISO 230-3 is important for the increasing number of simultaneously moving axes.

Measuring setup

Due to the different possibilities for mounting on the machine (rotary and tilting axes, various diameters of rotary tables, etc.), the customer must install the reference angle encoder himself.

A stiff connection between the stator and rotor of the reference encoder must be ensured. Since a certain amount of torque is needed in order for the reference encoder to move, the measuring accuracy will be affected if the connection is not rigid enough.

A connecting element with length L and diameter D between the shaft of the reference encoder and the stationary part of the measuring setup becomes twisted as shown in the graph. It is only of subordinate importance whether the shaft is solid or hollow.

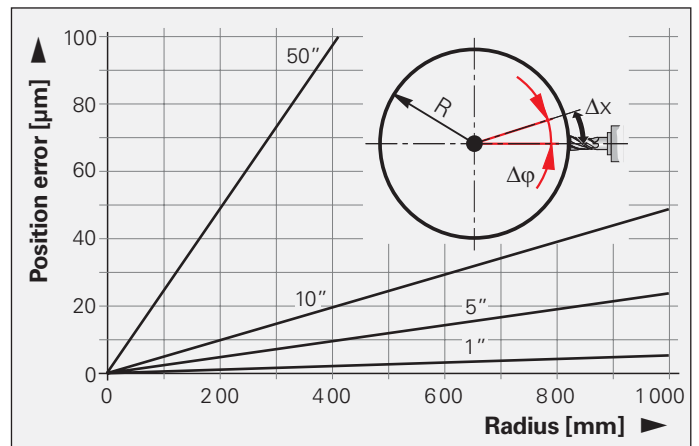
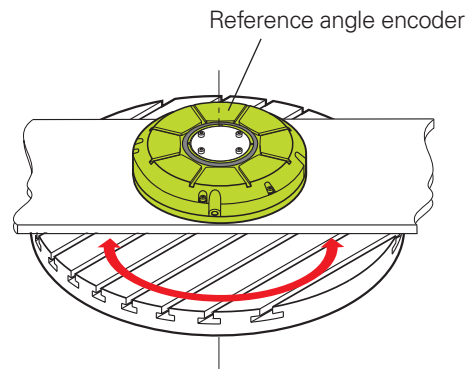

Influence of the distance R of the machining position from the center of the rotary table on the positioning accuracy Δx at various angular errors $\Delta\phi$ of the rotary table

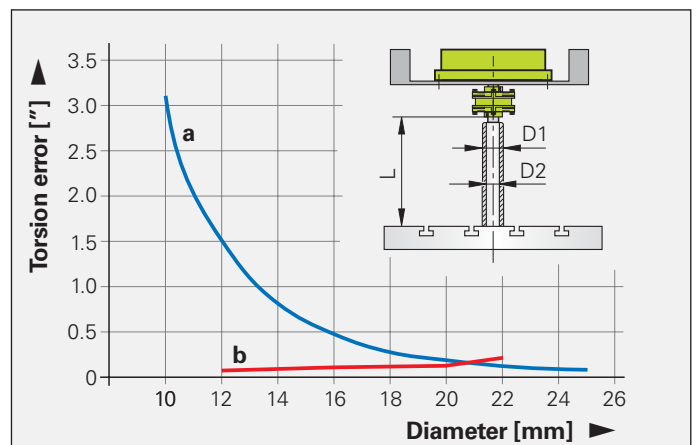

Torsion error of the 100-mm long coupling of an ROD 880 via a
a) Solid shaft with various diameters $D1$
b) Hollow shaft with outside diameter $D1 = 25$ mm and various inside diameters $D2$

Angle Encoders for the Measurement of Rotary Axes

Due to their accuracy and mechanical versions, the angle encoders listed here are especially suited for the measurement of rotary axes. They have integral bearings, but are coupled to the shaft differently:

The shaft of the **ROD 880** is connected via a separate shaft coupling to the shaft to be measured. Suitable shaft couplings, such as a K01 diaphragm coupling or K16 and K17 flat couplings are described in the *Angle Encoders with Integral Bearing* catalog.

RON 886 and **RPN 886** encoders have an integrated stator coupling. The shaft to be measured is directly connected with the hollow through shaft.

The **RON 905** also has an integrated stator coupling. The shaft to be measured is directly connected with the blind hollow shaft.

	ROD 880	RON 886	RPN 886	RON 905
System accuracy	± 1"			± 0.4"
Incremental signals	~ 1 V _{pp}			~ 11 μA _{pp}
Line count	36000		90000 (≅ 180000 signal periods)	36000
Measuring step with IK 220	0.000005°		0.0000005°	0.000005°
Shaft	Solid shaft D = 14 mm	Hollow through shaft D = 60 mm		Blind hollow shaft
Starting torque	≤ 0.012 Nm at 20 °C	≤ 0.5 Nm at 20 °C		≤ 0.005 Nm at 20 °C
Shaft load <i>axial</i> <i>radial</i>	30 Nm; 30 Nm at shaft end	-		-
Weight	Approx. 2.0 kg	Approx. 2.5 kg		Approx. 4.0 kg

ROD 880

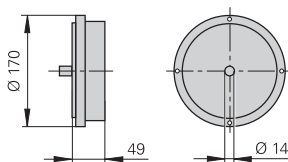

RON 886/RPN 886

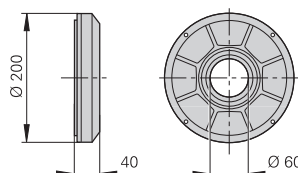

RON 905

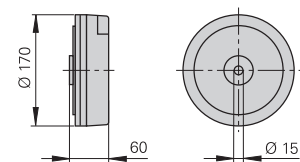

For more information, see the *Angle Encoders with Integral Bearing* catalog

Accessories

IK 220 – Counter Card

The IK 220 is a counter card for PCs with two inputs for linear and angular measurement with HEIDENHAIN position encoders (such as KGM or VM). It is inserted directly into a free PCI slot in the computer.

The IK 220 subdivides the periods of the sinusoidal encoder signals 4096-fold. The encoder signals are called and evaluated either by software or through adjustable internal timers. The positions thus determined are processed in the PC with the ACCOM evaluation software. The user can also program his own applications with the aid of the driver software. Example programs are included with the IK 220.

The IK 220 is ideal for applications requiring high-resolution encoder signals and rapid capture of measuring values.

Items supplied:

- IK 220
- Driver software
- Demonstration program



	IK 220			
Input signals (switchable)	~ 1 V _{PP}	~ 11 μA _{PP}	EnDat 2.1	SSI
Encoder input	2 D-sub connections (15-pin) male			
Max. input frequency	500 kHz	33 kHz	–	
Max. cable length	60 m		10 m	
Signal subdivision (signal period : meas. step)	Up to 4096-fold			
Data register for measured values (per channel)	48 bits (44 bits used)			
Internal memory	For 8 192 position values			
Interface	PCI bus (plug and play)			
Driver software and demonstration program	For Windows 98/NT/2000/XP in VISUAL C++, VISUAL BASIC and BORLAND DELPHI			
Dimensions	Approx. 190 mm x 100 mm			

Adapter Cables

The cables necessary for connecting the encoders to the IK 220 subsequent electronics are available as accessories. The maximum cable length of 10 m should not be exceeded.

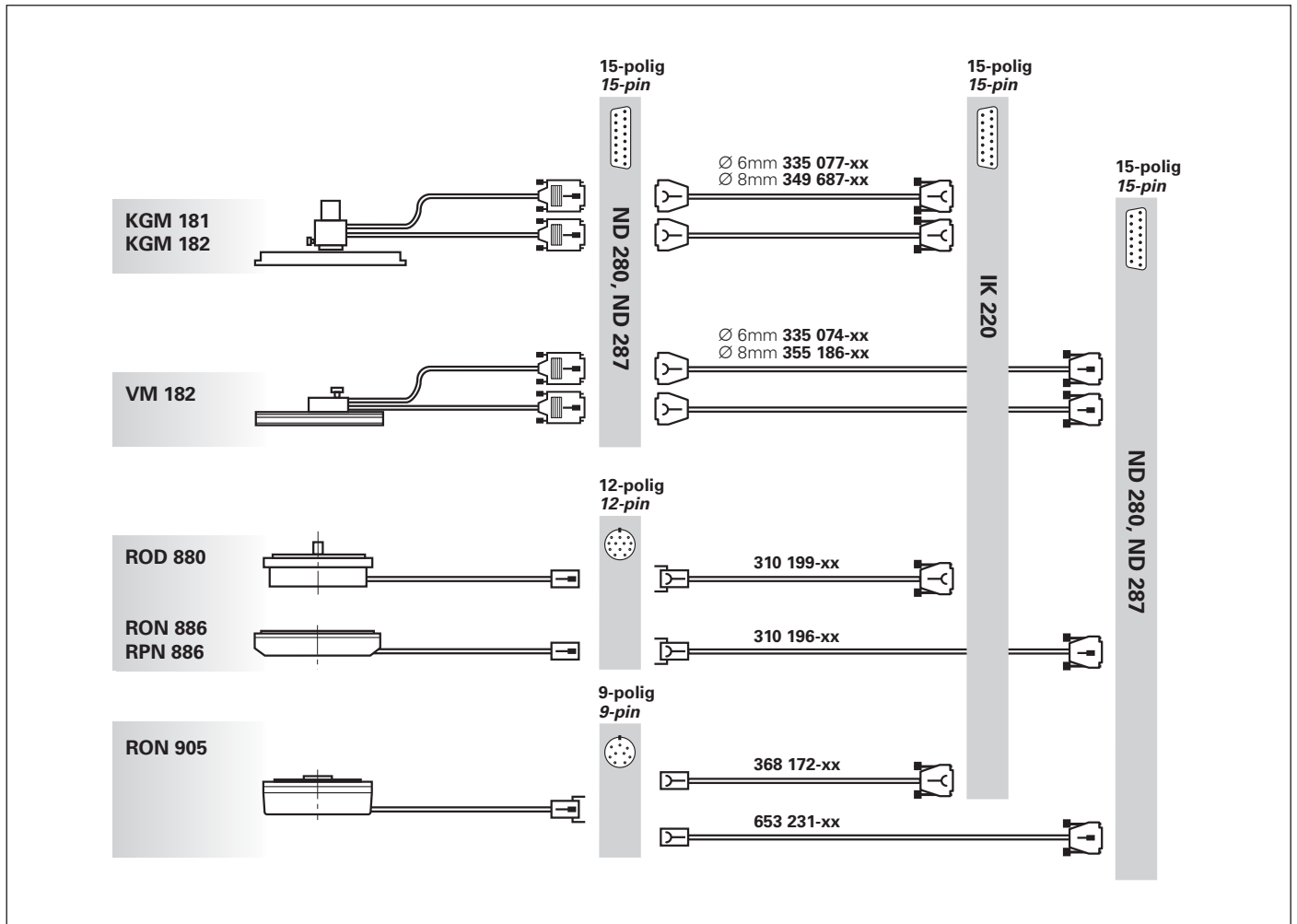

Application Examples



Free-form test with KGM 182



Determining the positioning accuracy with a VM 182

HEIDENHAIN

DR. JOHANNES HEIDENHAIN GmbH

Dr.-Johannes-Heidenhain-Straße 5

83301 Traunreut, Germany

☎ +49 (8669) 31-0

FAX +49 (8669) 5061

E-Mail: info@heidenhain.de

www.heidenhain.de

DE HEIDENHAIN Technisches Büro Nord

12681 Berlin, Deutschland

☎ (030) 54705-240

E-Mail: tbn@heidenhain.de

HEIDENHAIN Technisches Büro Mitte

08468 Heinsdorfergrund, Deutschland

☎ (03765) 69544

E-Mail: tbm@heidenhain.de

HEIDENHAIN Technisches Büro West

44379 Dortmund, Deutschland

☎ (0231) 618083-0

E-Mail: tbw@heidenhain.de

HEIDENHAIN Technisches Büro Südwest

70771 Leinfelden-Echterdingen, Deutschland

☎ (0711) 993395-0

E-Mail: tbsw@heidenhain.de

HEIDENHAIN Technisches Büro Südost

83301 Traunreut, Deutschland

☎ (08669) 31-1345

E-Mail: tbs0@heidenhain.de

AR NAKASE SRL.

B1653AOX Villa Ballester, Argentina

☎ +54 (11) 47684242

E-Mail: nakase@nakase.com

AT HEIDENHAIN Techn. Büro Österreich

83301 Traunreut, Germany

☎ +49 (8669) 31-1337

E-Mail: tba@heidenhain.de

AU FCR Motion Technology Pty. Ltd

Laverton North 3026, Australia

☎ +61 (3) 93626800

E-Mail: vicsales@fcrmotion.com

BE HEIDENHAIN NV/SA

1760 Roosdaal, Belgium

☎ +32 (54) 343158

E-Mail: sales@heidenhain.be

BG ESD Bulgaria Ltd.

Sofia 1172, Bulgaria

☎ +359 (2) 9632949

E-Mail: info@esd.bg

BR DIADUR Indústria e Comércio Ltda.

04763-070 – São Paulo – SP, Brazil

☎ +55 (11) 5696-6777

E-Mail: diadur@diadur.com.br

BY Belarus → RU

CA HEIDENHAIN CORPORATION

Mississauga, Ontario L5T 2N2, Canada

☎ +1 (905) 670-8900

E-Mail: info@heidenhain.com

CH HEIDENHAIN (SCHWEIZ) AG

8603 Schwerzenbach, Switzerland

☎ +41 (44) 8062727

E-Mail: verkauf@heidenhain.ch

CN DR. JOHANNES HEIDENHAIN

(CHINA) Co., Ltd.

Beijing 101312, China

☎ +86 10-80420000

E-Mail: sales@heidenhain.com.cn

CS Serbia and Montenegro → BG

CZ HEIDENHAIN s.r.o.

106 00 Praha 10, Czech Republic

☎ +420 272658131

E-Mail: heidenhain@heidenhain.cz

DK TP TEKNIK A/S

2670 Greve, Denmark

☎ +45 (70) 100966

E-Mail: tp-gruppen@tp-gruppen.dk

ES FARRESA ELECTRONICA S.A.

08028 Barcelona, Spain

☎ +34 934092491

E-Mail: farresa@farresa.es

FI HEIDENHAIN Scandinavia AB

02770 Espoo, Finland

☎ +358 (9) 8676476

E-Mail: info@heidenhain.fi

FR HEIDENHAIN FRANCE sarl

92310 Sèvres, France

☎ +33 0141143000

E-Mail: info@heidenhain.fr

GB HEIDENHAIN (G.B.) Limited

Burgess Hill RH15 9RD, United Kingdom

☎ +44 (1444) 247711

E-Mail: sales@heidenhain.co.uk

GR MB Milionis Vassilis

17341 Athens, Greece

☎ +30 (210) 9336607

E-Mail: bmilioni@otenet.gr

HK HEIDENHAIN LTD

Kowloon, Hong Kong

☎ +852 27591920

E-Mail: service@heidenhain.com.hk

HR Croatia → SL

HU HEIDENHAIN Kereskedelmi Képviselet

1239 Budapest, Hungary

☎ +36 (1) 4210952

E-Mail: info@heidenhain.hu

ID PT Servitama Era Toolsindo

Jakarta 13930, Indonesia

☎ +62 (21) 46834111

E-Mail: ptset@group.gts.co.id

IL NEUMO VARGUS MARKETING LTD.

Tel Aviv 61570, Israel

☎ +972 (3) 5373275

E-Mail: neumo@neumo-vargus.co.il

IN ASHOK & LAL

Chennai – 600 030, India

☎ +91 (44) 26151289

E-Mail: ashoklal@satyam.net.in

IT HEIDENHAIN ITALIANA S.r.l.

20128 Milano, Italy

☎ +39 02270751

E-Mail: info@heidenhain.it

JP HEIDENHAIN K.K.

Tokyo 102-0073, Japan

☎ +81 (3) 3234-7781

E-Mail: sales@heidenhain.co.jp

KR HEIDENHAIN LTD.

Gasan-Dong, Seoul, Korea 153-782

☎ +82 (2) 2028-7430

E-Mail: info@heidenhain.co.kr

MK Macedonia → BG

MX HEIDENHAIN CORPORATION MEXICO

20235 Aguascalientes, Ags., Mexico

☎ +52 (449) 9130870

E-Mail: info@heidenhain.com

MY ISOSERVE Sdn. Bhd

56100 Kuala Lumpur, Malaysia

☎ +60 (3) 91320685

E-Mail: isoserve@po.jaring.my

NL HEIDENHAIN NEDERLAND B.V.

6716 BM Ede, Netherlands

☎ +31 (318) 581800

E-Mail: verkoop@heidenhain.nl

NO HEIDENHAIN Scandinavia AB

7300 Orkanger, Norway

☎ +47 72480048

E-Mail: info@heidenhain.no

PH Machinebanks Corporation

Quezon City, Philippines 1113

☎ +63 (2) 7113751

E-Mail: info@machinebanks.com

PL APS

02-489 Warszawa, Poland

☎ +48 228639737

E-Mail: aps@apserwis.com.pl

PT FARRESA ELECTRÓNICA, LDA.

4470 - 177 Maia, Portugal

☎ +351 229478140

E-Mail: fep@farresa.pt

RO Romania → HU

RU OOO HEIDENHAIN

125315 Moscow, Russia

☎ +7 (495) 931-9646

E-Mail: info@heidenhain.ru

SE HEIDENHAIN Scandinavia AB

12739 Skärholmen, Sweden

☎ +46 (8) 53193350

E-Mail: sales@heidenhain.se

SG HEIDENHAIN PACIFIC PTE LTD.

Singapore 408593,

☎ +65 6749-3238

E-Mail: info@heidenhain.com.sg

SK Slovakia → CZ

SL Posredništvo HEIDENHAIN

SAŠO HÜBL s.p.

2000 Maribor, Slovenia

☎ +386 (2) 4297216

E-Mail: hubl@siol.net

TH HEIDENHAIN (THAILAND) LTD

Bangkok 10250, Thailand

☎ +66 (2) 398-4147-8

E-Mail: info@heidenhain.co.th

TR T&M Mühendislik San. ve Tic. LTD. ŞTİ.

34738 Erenköy-Istanbul, Turkey

☎ +90 (216) 3022345

E-Mail: info@tmmuhendislik.com.tr

TW HEIDENHAIN Co., Ltd.

Taichung 407, Taiwan

☎ +886 (4) 23588977

E-Mail: info@heidenhain.com.tw

UA Ukraine → RU

US HEIDENHAIN CORPORATION

Schaumburg, IL 60173-5337, USA

☎ +1 (847) 490-1191

E-Mail: info@heidenhain.com

VE Maquinaria Diekmann S.A.

Caracas, 1040-A, Venezuela

☎ +58 (212) 6325410

E-Mail: purchase@diekmann.com.ve

VN AMS Advanced Manufacturing

Solutions Pte Ltd

HCM City, Việt Nam

☎ +84 (8) 9123658 - 8352490

E-Mail: davidgoh@amsvn.com

ZA MAFEMA SALES SERVICES C.C.

Midrand 1685, South Africa

☎ +27 (11) 3144416

E-Mail: mailbox@mafema.co.za

