



# HEIDENHAIN

Votre agent :

**araxe**

72, rue Yves le Coz  
78000 - VERSAILLES

tél : 01 30 21 48 49  
contact@araxe.com

<http://www.araxe.com>



Software Function

## **KinematicsOpt**

Calibration of Rotary Axes and  
Compensation of the Drift

October 2009

# KinematicsOpt

## Software Option for the Calibration of Rotary Axes

The share of five-axis milling machines on the market has continued to grow in recent years. Thanks to the capabilities of these machines, complex workpieces can often be machined in just one setup. As a result, additional fixtures are not necessary, downtimes are reduced, and there are fewer sources of error.

### Axis movements influence the accuracy of the workpiece

But caution is necessary: a workpiece can only be machined precisely if the machine itself can exactly trace the transformations of the coordinate system that occur as the result of rotational movements. When programming milling machines with four or more axes, the programmer concentrates on tilting the respective working plane, and then enters the coordinates based on this system. The PLANE function of the TNC controls offers optimum support in this regard. Although the programmer has almost no chance to foresee the actual movements of the machine, the control can calculate the appropriate transformations of the workpiece coordinate system, and commands the necessary movements of the axes.

A kinematic transformation chain of the machine is stored in the TNC for this purpose. The more this model matches the real machine, the more exactly the control can calculate the actual movements. As a result, the dimensional accuracy of the finished workpiece is improved. The dimensions entered for this kinematic transformation chain are usually determined during designing of the machine and commissioning by the machine manufacturer. Later corrections by service technicians are also possible. Conventional determination of this data is performed in very different manners, and requires well-trained specialists.

Nowadays thermal influences are a serious problem regarding the accuracy of machine tools. Every machine is affected by numerous thermal sources, whose influences on the machine differ depending on the machining process. If the machine is not located in a climatized environment, then external factors play a significant additional role. Especially during the production of single parts or small lots, often with longer downtimes, the machine components are subjected to relatively strong temperature variations. Depending on its design, each machine model reacts differently to these temperature variations. This means that if the real machine were to undergo changes during machining due to thermal influences, then the kinematic transformation chain would need to be adapted accordingly.

### Measuring the machine kinematics

The iTNC 530 control from HEIDENHAIN supports the operator during this complex task with the **KinematicsOpt** software option. It consists of probing cycles that are fully integrated in the iTNC 530 (as of software 34049x-04). The principle behind KinematicsOpt is very simple: A 3-D touch

trigger probe, such as the TS 740 from HEIDENHAIN, is used to measure the position of an exactly dimensioned calibration sphere from various rotated axis positions. The operator then receives a log stating the actual accuracy during tilting at the current point in time. If desired, KinematicsOpt can automatically optimize the axes that have been measured. The necessary modifications to the machine data are made automatically: the operator does not need any detailed knowledge about the kinematic configuration of the machine.

This measuring procedure with KinematicsOpt only takes several minutes, and enables the operator to recalibrate his milling machine himself. If the calibration sphere is permanently mounted on the machine table, then this procedure can even be performed as an automated step between the individual machining processes. This makes it possible to achieve a consistently high level of quality, both in series production and in single-part production.

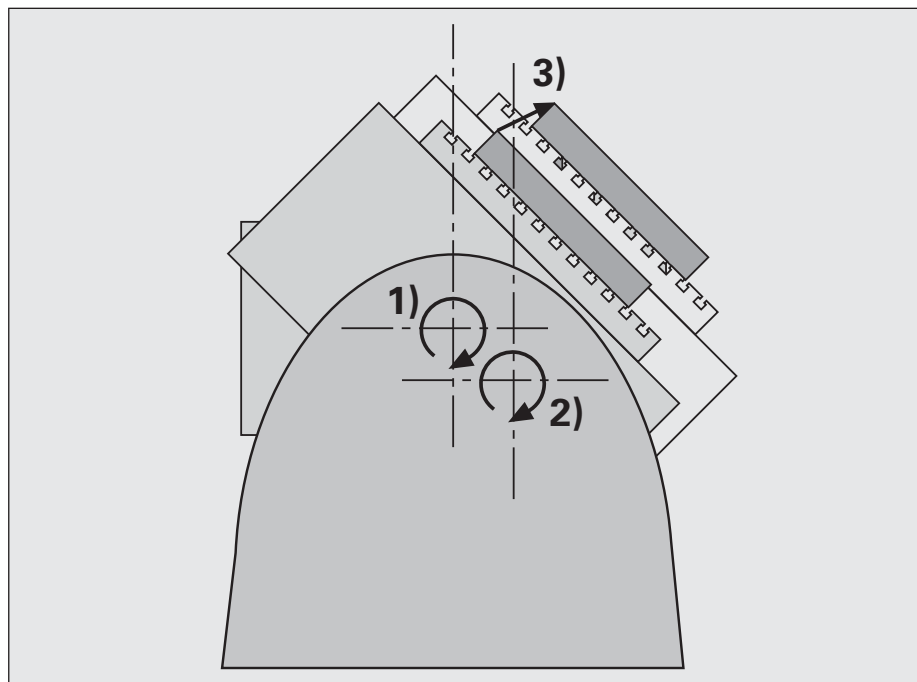

- 1) Position of the rotary axis in the kinematics model of the control
- 2) Actual position of the rotary axis
- 3) Resulting position error during tilting

### Storing the determined machine configuration

Since the existing kinematic configuration is changed with each recalibration, it is useful to make backups of the data. That way, configurations already determined can easily be restored at a later point in time. This provides security should something go wrong during measurement, such as a power failure occurring. The machine manufacturer can also protect his calibration data with a password.

### Calibration of interchangeable heads

Large milling machines in particular make use of interchangeable heads. Since the dimensions of each head differ, the control's calculations must include different kinematic transformation chains. In order to prevent a separate workpiece datum from being necessary for each head, the heads are calibrated relative to each other. The differences in the dimensions are stored in the iTNC 530. Should the dimensions of a head change, i.e. due to being exchanged, after a crash, or even because of thermal influences, then this head must be

recalibrated relative to the other heads. Since this requires in-depth knowledge of the control's kinematic transformation chain, this procedure used to be the sole domain of the manufacturer. Now, with KinematicsOpt, the operator can calibrate an interchangeable head himself, even without detailed information about the kinematic configuration. All he needs is a 3-D touch probe and a calibration sphere. The operator specifies a reference tool head, which must already be optimally calibrated. The interchangeable heads are then calibrated in the same manner, and compared to each other. The calibration sphere serves as reference point, and remains fixed in place on the machine table during the measurement procedures.

### Compensation of the drift

KinematicsOpt can even be used on machines with just three axes. The drift of the machine components is captured and stored on the control. This practically leads to compensation of this drift, without needing to include datum shifts in the machining program.

### The cycles of KinematicsOpt

KinematicsOpt mainly consists of three touch-probe cycles:

- Cycle 451  
MEASURE KINEMATICS for calibrating the machine kinematics
- Cycle 452  
PRESET COMPENSATION for calibrating interchangeable heads and drift compensation
- Cycle 450  
SAVE KINEMATICS for storing the determined machine configuration

The operator carries out the cycles in the usual manner. With graphic and conversational support, he assigns values to the input parameters for the cycles, which are structured identically for each kinematic machine configuration. The number and position of the measuring points can be defined individually, making the cycles optimally adaptable to all types of machines and requirements.

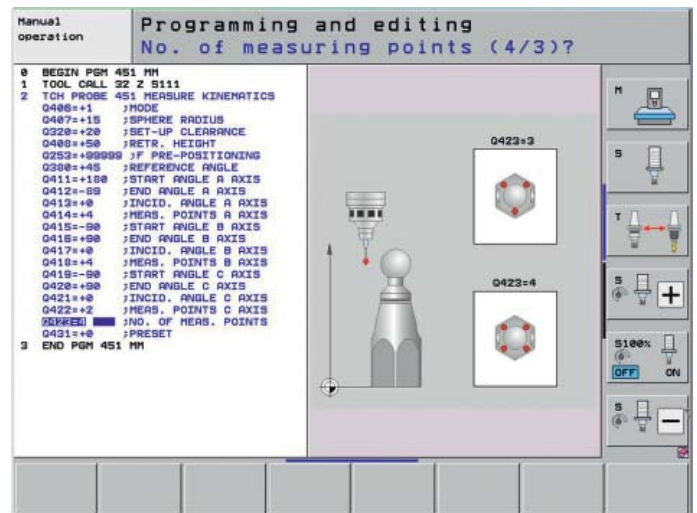

# KinematicsOpt Components

The following components are necessary accessories for KinematicsOpt:

## Calibration sphere with holder

The KKH 100 and KKH 250 calibration spheres have holders with different lengths, and are characterized by their especially high rigidity.

Calibration sphere	KKH 100	KKH 250
Length L	100 mm	250 mm
D1	Ø 25 mm	Ø 25 mm
Width A/F (SW)	40	50
ID	655475-02	655475-01

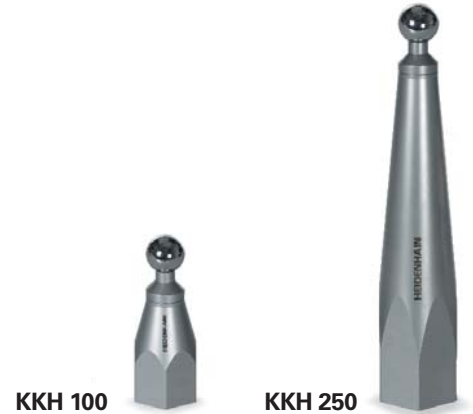
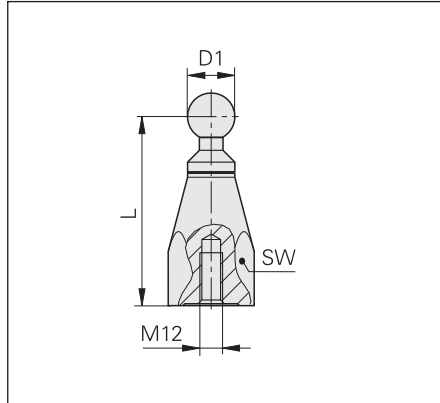

## Touch probe

A 3-D touch probe from HEIDENHAIN, which is often already in place on the machine tool and is mainly used for aligning and measuring workpieces as well as for datum setting, serves to probe the calibration sphere.

The TS 740 piezoresistive touch probe is particularly suited for measuring the rotary axes in combination with KinematicsOpt, since its repeatability is far below 1 µm. Naturally the standard TS 640 and TS 440 touch probes can also be used.

The blowing unit integrated in the touch probes from HEIDENHAIN removes contaminants from the probing point, and ensures that the measuring process is as reliable as possible.

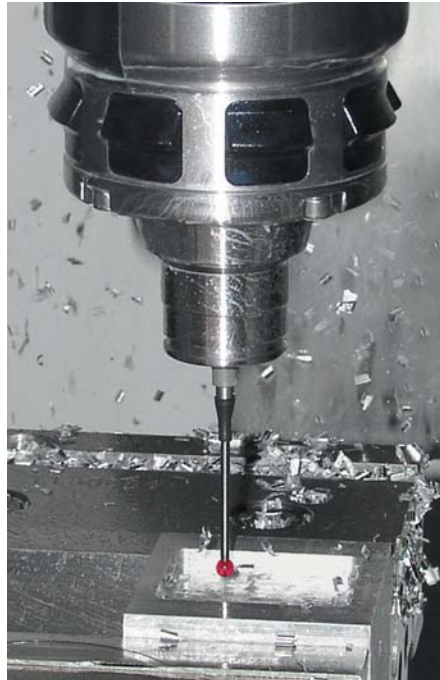

	TS 740		TS 440 TS 640
Probe velocity	≤ 0.25 m/min	≤ 0.5 m/min	≤ 1 m/min
Probe repeatability	≤ 0.25 µm	≤ 0.6 µm	≤ 1 µm
Deflection of the calibration-sphere holder due to the deflection force of the TS	KKH 100: typ. 0.2 µm KKH 250: typ. 0.8 µm		KKH 100: typ. 1 µm KKH 250: typ. 2 µm

# HEIDENHAIN

**DR. JOHANNES HEIDENHAIN GmbH**  
Dr.-Johannes-Heidenhain-Straße 5  
**83301 Traunreut, Germany**  
☎ +49 8669 31-0  
FAX +49 8669 5061  
E-mail: info@heidenhain.de

[www.heidenhain.de](http://www.heidenhain.de)

For catalogs, brochures and product information sheets, visit [www.heidenhain.de/docu](http://www.heidenhain.de/docu)

### For more information

- iTNC 530 brochure
- Touch Probes brochure