



HEIDENHAIN



**Functional
Safety**

Product Information

ECN 1023

EQN 1035

Rotary Encoders with
EnDat 2.2 for
Safety-Related Applications

January 2009

	Absolute	
	ECN 1023 – Singleturn	EQN 1035 – Multiturn
Safety-related data	Applicable as single-encoder system in the control loop for applications of the control category <ul style="list-style-type: none"> • SIL 2 (Safety Integrity Level) according to DIN EN IEC 61508 • PL "d" (Performance Level) according to DIN EN ISO 13849 • Category 3 according to EN 954-1 Safe in the singleturn range	
PFH	$\leq 1 \times 10^{-8}$ (probability of dangerous failure per hour)	
Angular error of the safe position	$\leq \pm 0.7^\circ$ (9 bits)	
Absolute position values	EnDat 2.2	
Ordering designation	EnDat 22	
Position values per revolution	8388608 (23 bits)	
Revolutions	–	4096 (12 bits)
Elec. permissible speed	$\leq 12000 \text{ min}^{-1}$ (for continuous position value)	
Calculation time t_{cal}	$\leq 5 \mu\text{s}$	
System accuracy	$\pm 60''$	
Power supply	3.6 to 14 V–	
Max. current consumption ¹⁾	$\leq 165 \text{ mA}$	$\leq 195 \text{ mA}$
Electrical connection	Cable 1 m, with M12 coupling	
Cable length	$\leq 100 \text{ m}$	
Shaft	Blind hollow shaft $\varnothing 6 \text{ mm}$	
Mech. permissible speed n	$\leq 12000 \text{ min}^{-1}$	
Starting torque at 20 °C	$\leq 0.001 \text{ Nm}$	$\leq 0.002 \text{ Nm}$
Moment of inertia of rotor	$0.5 \cdot 10^{-6} \text{ kgm}^2$	
Angular acceleration of rotor	$\leq 1 \times 10^5 \text{ rad/s}^2$	
Natural frequency of the stator coupling	$\geq 1800 \text{ Hz}$	
Permissible axial motion of measured shaft	$\pm 0.5 \text{ mm}$ (see ☺ in mating dimensions)	
Vibration 10 to 2000 Hz ²⁾ Shock 6 ms	$\leq 100 \text{ m/s}^2$ (EN 60068-2-6) $\leq 1000 \text{ m/s}^2$ (EN 60068-2-27)	
Max. operating temperature ³⁾	100 °C	
Min. operating temperature ³⁾	For rigid configuration: –30 °C For frequent flexing: –10 °C	
Relative humidity	$\leq 93 \%$ (40 °C/21 d according to EN 60068-2-78) Without condensation	
Protection EN 60529	IP 64	
Weight	Approx. 0.1 kg	

¹⁾ Depends on the power supply; see *General Electrical Information*

²⁾ 10 to 55 Hz constant over distance 4.9 mm peak to peak

³⁾ For measuring point of operating temperature range, see ☺ in mating dimensions

General Electrical Information

Power Supply

The encoders require a **stabilized dc voltage U_p** as power supply. The required power supply and the current consumption are given in the respective specifications. The values apply as measured at the encoder, i.e., without cable influences.

Connect HEIDENHAIN encoders only to subsequent electronics whose power supply is generated from PELV systems (**EN 50 178**). In addition, in safety-related applications, overcurrent protection and sometimes overvoltage protection are required.

Isolation

The encoder housings are isolated against internal circuits.

Rated surge voltage: 500 V
(preferred value as per VDE 0110 Part 1; overvoltage category II, contamination level 2)

Current consumption

For encoders with extended voltage range (3.6 V to 14 V), the current consumption depends on the actual supply voltage. In the specifications it is stated for a 3.6-V supply (maximum value). These diagrams show the actual current consumption for different operating situations depending on the respective supply voltage values:

- Without load (only power supply connected)
- With load (normal operation with position value request at 8 MHz)
- Maximum value (additionally with aging and possible temperature influences)

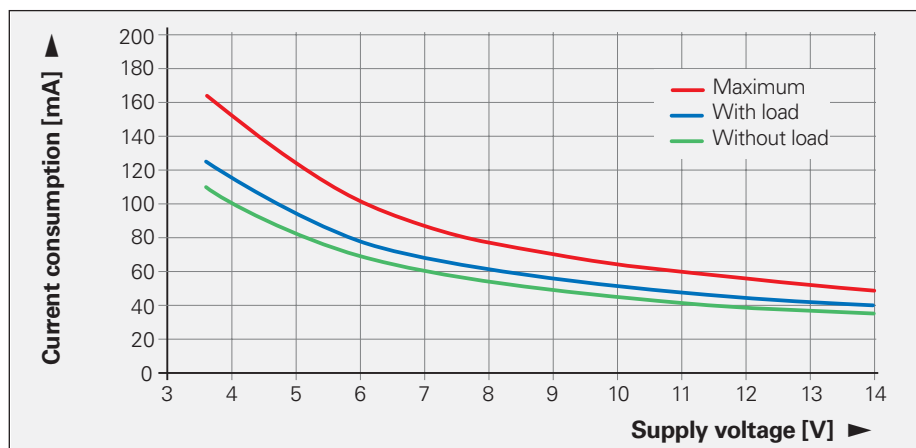

Current consumption of the ECN singleturn rotary encoders

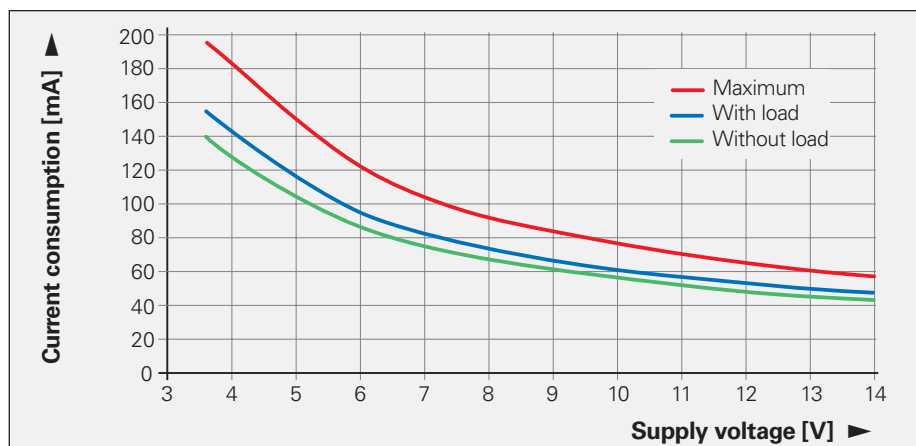

Current consumption of the EQN multiturn rotary encoders

Cables

HEIDENHAIN cables with connectors are mandatory for use in safety-related applications.

Lengths

The cable lengths listed in the *Specifications* apply only for HEIDENHAIN cables and the recommended input circuitry of subsequent electronics.

Durability

All encoders have polyurethane (PUR) cables. PUR cables are resistant to oil, hydrolysis and microbes in accordance with **VDE 0472**. They are free of PVC and silicone and comply with UL safety directives. The **UL certification** AWM STYLE 20963 80 °C 30 V E63216 is documented on the cable.

Encoder cables in the motor housing usually have a sheathing of a special elastomer (EPG). They are resistant to oil in accordance with VDE 0472, hydrolysis-resistant and free of PVC, silicone and halogen. In comparison with PUR cables, EPG cables are only conditionally resistant to media, frequent flexing and continuous torsion. In rigid configuration they can be used up to 120 °C. The smallest permissible bending radius is 18 mm.

Temperature range

HEIDENHAIN cables can be used for	
rigid configuration (PUR)	-40 to 80 °C
rigid configuration (EPG)	-40 to 120 °C
frequent flexing	-10 to 80 °C

PUR cables with limited resistance to hydrolysis and microbes are rated for up to 100 °C. If required, please ask for assistance from HEIDENHAIN Traunreut.

Noise-Free Signal Transmission

Bend radius

The permissible bend radii R depend on the cable diameter and the configuration:

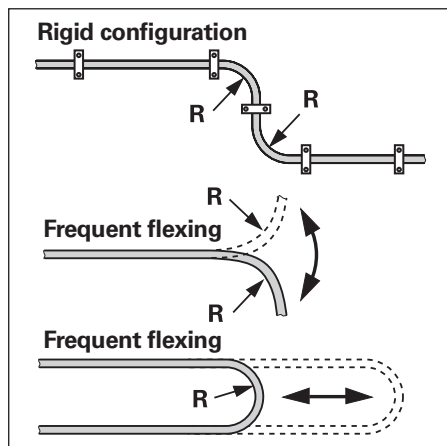

HEIDENHAIN cables	Rigid configuration	Frequent flexing
PUR Ø 4.5 mm	$R \geq 10 \text{ mm}$	$R \geq 50 \text{ mm}$
PUR Ø 6 mm	$R \geq 20 \text{ mm}$	$R \geq 75 \text{ mm}$
EPG Ø 4.5 mm	$R \geq 18 \text{ mm}$	–

Electromagnetic compatibility/ CE-compliance

When properly installed, and when HEIDENHAIN connecting cables and cable assemblies are used, HEIDENHAIN encoders fulfill the requirements for electromagnetic compatibility according to 89/336/EEC with respect to the generic standards for:

• Noise immunity IEC 61000-6-2:

- Specifically:
- ESD EN 61 000-4-2
 - Electromagnetic fields EN 61 000-4-3
 - Burst EN 61 000-4-4
 - Surge EN 61 000-4-5
 - Conducted disturbances EN 61 000-4-6
 - Power frequency magnetic fields EN 61 000-4-8
 - Pulse magnetic fields EN 61 000-4-9

• Interference EN 61000-6-4:

- Specifically:
- For industrial, scientific and medical equipment (ISM) EN 55011
 - For information technology equipment EN 55022

Transmission of measuring signals – electrical noise immunity

Noise voltages arise mainly through capacitive or inductive transfer. Electrical noise can be introduced into the system over signal lines and input or output terminals.

Possible sources of noise are:

- Strong magnetic fields from transformers, brakes and electric motors
- Relays, contactors and solenoid valves
- High-frequency equipment, pulse devices, and stray magnetic fields from switch-mode power supplies
- AC power lines and supply lines to the above devices

Protection against electrical noise

The following measures must be taken to ensure disturbance-free operation:

- Use only original HEIDENHAIN cables. Consider the voltage attenuation on supply lines.
- Use connecting elements (such as connectors or terminal boxes) with metal housings. Only the signals of and power supply for the connected encoder may be routed through these elements. Applications in which additional signals are led through the connecting element require specific measures regarding electrical safety and EMC.
- Connect the housings of the encoder, connecting elements and subsequent electronics through the shield of the cable. Ensure that the shield has complete contact over the entire surface (360°). For encoders with more than one electrical connection, refer to the documentation for the respective product.
- For cables with multiple shields, the inner shields must be led separately from the outer shield. Connect inner shield to 0V of the subsequent electronics. Do not connect the inner shields with the outer shield, neither in the encoder nor in the cable.
- Connect the shield to protective ground as per the mounting instructions.
- Prevent contact of the shield (e.g. connector housing) with other metal surfaces. Pay attention to this when installing cables.
- Do not install signal cables in the direct vicinity of interference sources (inductive consumers such as contacts, motors, frequency inverters, solenoids, etc.).
 - Sufficient decoupling from interference-signal-conducting cables can usually be achieved by an air clearance of 100 mm or, when cables are in metal ducts, by a grounded partition.
 - A minimum spacing of 200 mm to inductors in switch-mode power supplies is required.
- If compensating currents are to be expected within the overall system, a separate equipotential bonding conductor must be provided. The shield does not have the function of an equipotential bonding conductor.
- Only provide power to position encoders from PELV systems (EN 50178). Provide high-frequency grounding with low impedance (EN 60204-1 Chap. EMC).

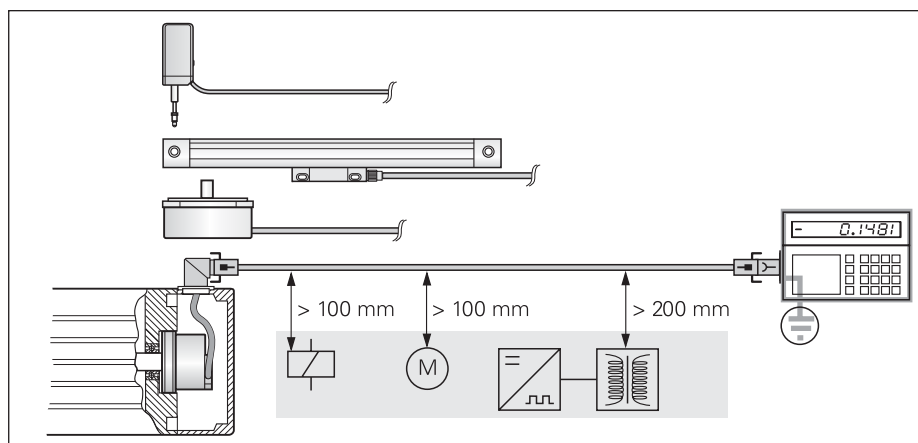





Minimum distance from sources of interference

Product Information ECN 1023, EQN 1035 1/2009

Electrical Connection





Cable with M12 connecting element, 8-pin

EnDat 22 without incremental signals

PUR connecting cables		8-pin: [(4 × 0.14 mm ²) + (4 × 0.34 mm ²)] Ø 6 mm
Complete with connector (female) and coupling (male)		368330-xx
Complete with connector (female) and D-sub connector (female) for IK 220		533627-xx
Complete with connector (female) and D-sub connector (male) for IK 115/IK 215		524599-xx
With one connector (female)		559346-xx ¹⁾

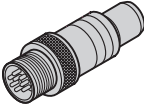
¹⁾ Connecting element must be suitable for 8 MHz signal transmission.

Pin layout

8-pin coupling M12								
			Power supply			Absolute position values		
	8	2	5	1	3	4	7	6
	U_P	Sensor U_P	0V	Sensor 0V	DATA	DATA	CLOCK	CLOCK
	Brown/Green	Blue	White/Green	White	Gray	Pink	Violet	Yellow

Shield on housing; **U_P** = Power supply voltage

Vacant pins or wires must not be used!

The sensor line is connected inside the encoder to the supply line.

HEIDENHAIN cables, complete with connectors, are required for use in safety-related applications!

HEIDENHAIN

DR. JOHANNES HEIDENHAIN GmbH

Dr.-Johannes-Heidenhain-Straße 5

83301 Traunreut, Germany

☎ +49 (8669) 31-0

FAX +49 (8669) 5061

E-mail: info@heidenhain.de

www.heidenhain.de

Related documents

- Mounting Instructions *ECN 1023, EQN 1035* 619076-xx
- Technical Information: *Safety-Related Position Encoders* 596632-xx
- Interface Description: *EnDat* 297403-xx
- System specification: *Specification of the E/E/PES safety requirements for the EnDat master and measures for the safe control* 533095-xx