



HEIDENHAIN



Product Information

ERM 2400 Series Magnetic Built-in Encoders

September 2007

ERM 2400 Series

- Built-in encoders
- Magnetic scanning principle
- Compact dimensions

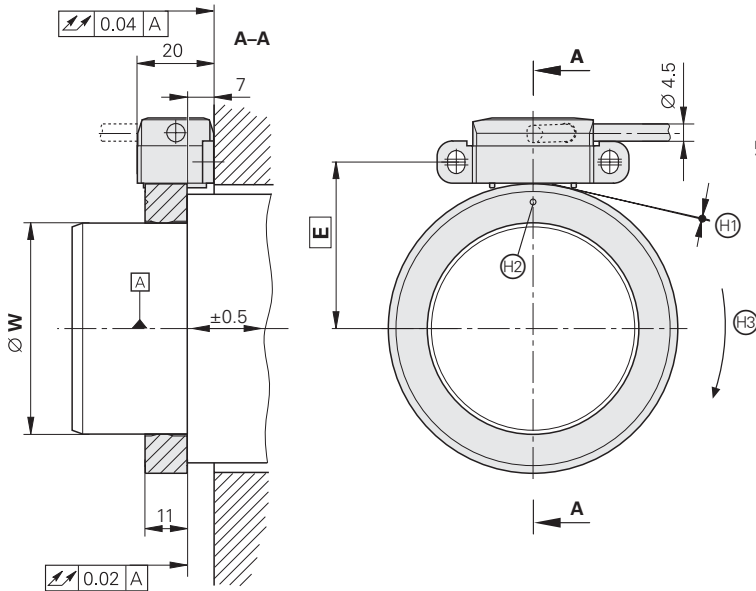

ERM 2480 scanning head

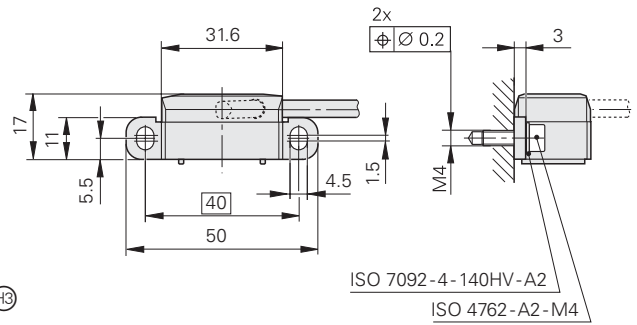

ERM 2404 scale drum

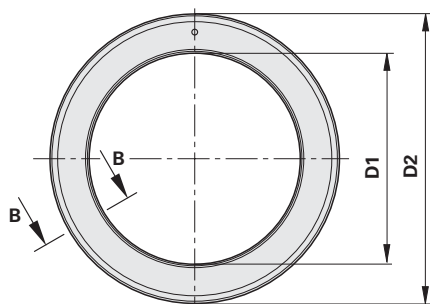

ERM 2405 scale drum

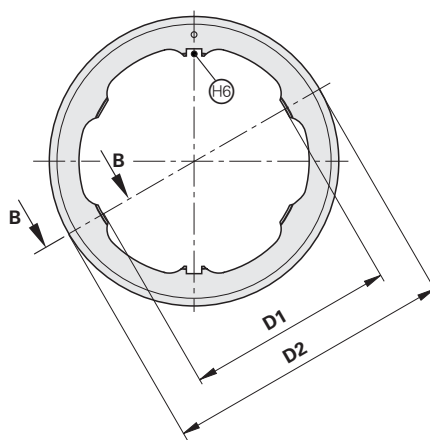

Dimensions in mm

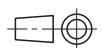

Tolerancing ISO 8015
ISO 2768 - m H
< 6 mm: ±0.2 mm

- ⊠ = Bearing
- ⊕ = Mounting distance of 0.15 mm set with spacer foil
- ⊙ = Reference mark
- ⊕ = Positive direction of rotation for output signals
- ⊕ = Centering collar
- ⊕ = Clamping area (applies to both sides)
- ⊕ = Slot for feather key 4x4x10 (as per DIN 6885 shape A)

D1	W	D2	E
∅ 40 + 0.010/+0.002	∅ 40 0/-0.006	∅ 64.37	37.9
∅ 55 + 0.010/+0.002	∅ 55 0/-0.006	∅ 75.44	43.4

	ERM 2484		ERM 2485	
Incremental signals	~ 1 V _{pp}			
Reference mark	One			
Cutoff frequency -3dB	≥ 300 kHz			
Power supply	5 V ± 10%			
Power consumption	≤ 150 mA (without load)			
Electrical connection*	Cable 1 m, with or without coupling; cable outlet axial or radial			
Cable length	≤ 150 m with HEIDENHAIN cable			
Drum inside diameter*	40 mm	55 mm	40 mm	55 mm
Drum outside diameter*	64.37 mm	75.44 mm	64.37 mm	75.44 mm
Line count	512	600	512	600
System accuracy¹⁾	± 43"	± 36"	± 43"	± 36"
Accuracy of graduation	± 17"	± 14"	± 17"	± 14"
Mech. perm. speed	≤ 42 000 min ⁻¹	≤ 36 000 min ⁻¹	≤ 33 000 min ⁻¹	≤ 27 000 min ⁻¹
Moment of inertia of the rotor	0.12 · 10 ⁻³ kgm ²	0.19 · 10 ⁻³ kgm ²	0.11 · 10 ⁻³ kgm ²	0.17 · 10 ⁻³ kgm ²
Perm. axial movement	± 0.5 mm			
Vibration 55 to 2 000 Hz Shock 6 ms	≤ 400 m/s ² (IEC 60 068-2-6) ≤ 1 000 m/s ² (IEC 60 068-2-27)			
Max. operating temperature	100 °C			
Min. operating temperature	-10 °C			
Protection IEC 60 529	IP 67			
Weight (approx.)				
Scale drum	0.17 kg	0.17 kg	0.15 kg	0.15 kg
Scanning head (without cable)	0.02 kg			

* Please indicate when ordering

¹⁾ Before installation. Additional errors caused by mounting inaccuracy and inaccuracy from the bearing of the drive shaft are not included.

Mechanical Design Types and Mounting

The ERM 2400 built-in encoders consist of a circumferential scale drum and the corresponding scanning head.

The scale drum is available in two versions. The inside of the **ERM 2404** scale drum is smooth. Only a force-fit connection (clamping of the drum) should be used to prevent it from rotating unintentionally. The **ERM 2405** scale drum features a keyway. The feather key is only intended for the prevention of unintentional rotation. The transmission of torque via the feather key is not permissible. A force-fit connection is to be used here, as with the ERM 2404 scale drum. The special shape of the drum's inside is designed to ensure stability even at the maximum permissible speeds.

Mounting





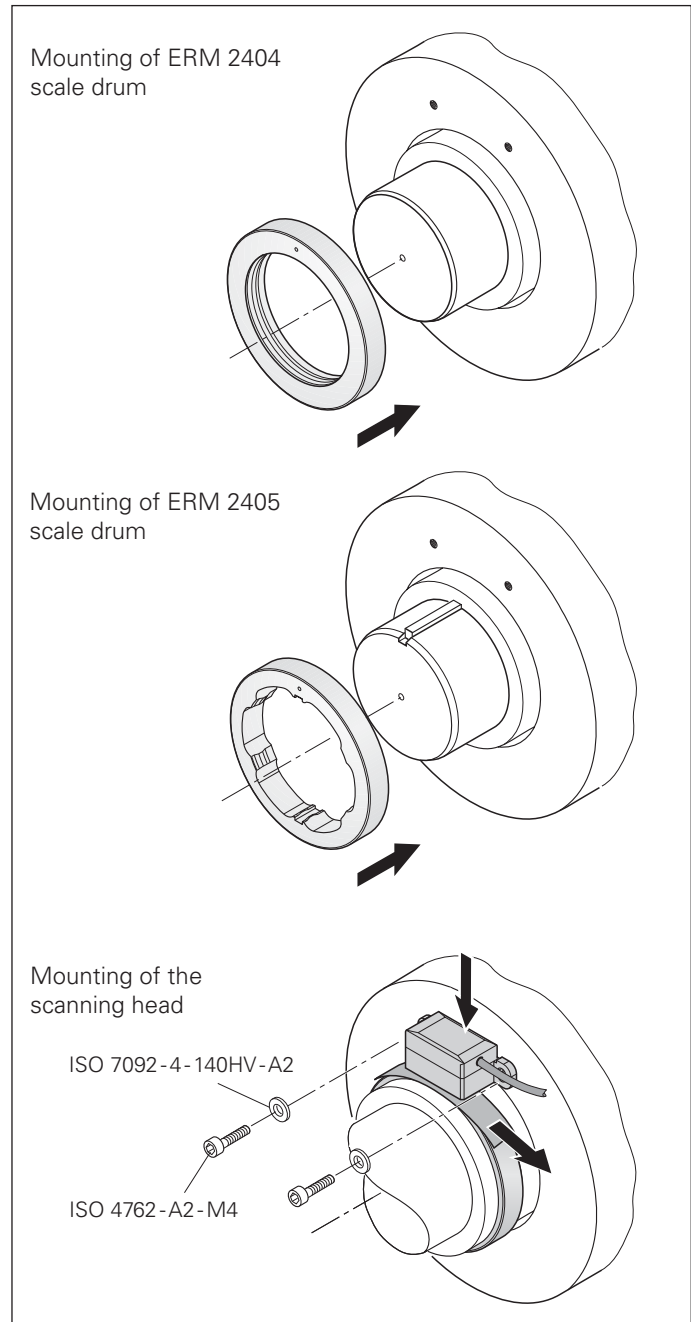

The **circumferential scale drum** is slid onto the drive shaft and clamped. The scale drum is centered via the centering collar on its inner circumference. In order to keep the eccentricity of the graduation to the bearing resulting from mounting to a minimum, and the resulting deviations in accuracy as well, the gap between the shaft and centering collar should be as small as possible. The clamping of the scale drum depends on the mounting situation. The clamping force must be applied evenly over the plane surface of the drum. The necessary mounting elements depend on the design of the customer's equipment, and are therefore the responsibility of the customer. The frictional connection must be strong enough to prevent unintentional rotation or skewing in axial and radial directions, even at high speeds and accelerations. The scale drum may not be modified for this purpose, such as by drilling holes or countersinks in it.

In order to mount the scanning head, the spacer foil is applied to the surface of the circumferential scale drum. The **scanning head** is pressed against the foil, fastened, and the foil is removed.

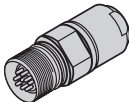
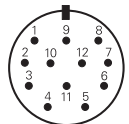
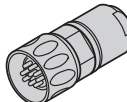

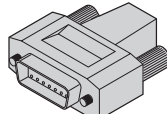
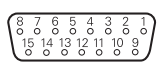
Electrical Connection

Pin layout





12-pin M23 coupling		12-pin M23 connector				15-pin D-sub connector, female for HEIDENHAIN controls and IK 220							
													
	Power supply				Incremental signals						Other signals		
	12	2	10	11	5	6	8	1	3	4	7/9	/	/
	1	9	2	11	3	4	6	7	10	12	5/8/13/14/15	/	/
	U _P	Sensor U _P	0 V	Sensor 0 V	A+	A-	B+	B-	R+	R-	Vacant	Vacant	Vacant
	Brown/ Green	Blue	White/ Green	White	Brown	Green	Gray	Pink	Red	Black	/	Violet	Yellow

Shield on housing; **U_P** = power supply voltage

Sensor: The sensor line is connected internally with the corresponding power line

Vacant pins or wires must not be used!

Connecting cables

PUR connecting cables	12-pin: [4(2 × 0.14 mm ²) + (4 × 0.5 mm ²)] Ø 8 mm	
Complete with M23 connector (female) and M23 coupling (male)		298401-xx
Complete with M23 connectors (female/male)		298399-xx
Complete with M23 connector (female) and D-sub connector (female) for IK 220		310199-xx
With one M23 connector (female)		309777-xx
Cable without connectors , Ø 8 mm		244957-01

For further information

See the *ERM 200 Product Information sheet*

Rückseite -Allgemein!!

636218-11 und -21